

CORSO LED V2 12-NW-SE
CORSO LED V2 18-NW-SE
CORSO LED V2 24-NW-SE

Aprisa s.r.o., Sadvá 618, 738 01 Frydek-Místek, Czech Republic

Table with 5 columns (P1-P5) and 3 rows (12W, 18W, 24W) showing technical specifications like luminous flux, beam diameter, and height.

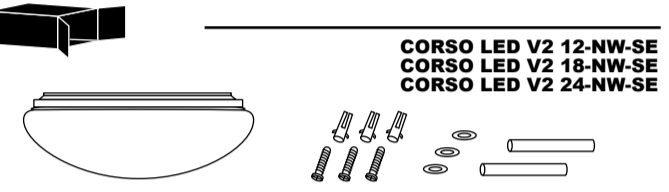
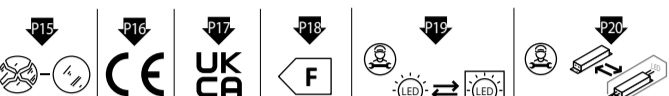
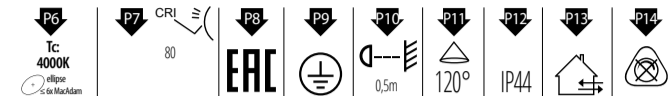

CORSO LED V2 12-NW-SE
CORSO LED V2 18-NW-SE
CORSO LED V2 24-NW-SE

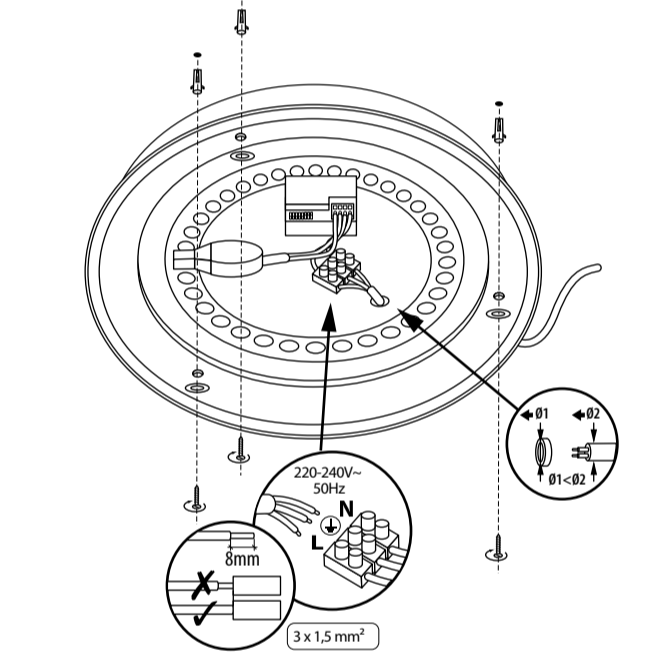
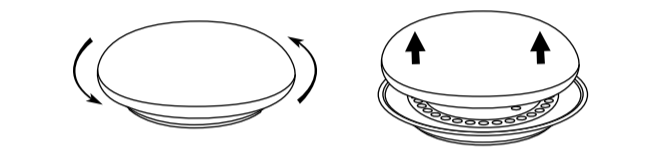

- P4: Rated luminous flux.
P5: Rated durability.
P6: Colour temperature.
P7: Colour Rendering Index.
P8: Certificate of Conformity confirming the quality of production in accordance with approved standards on the territory of the Customs Union.
P9: Class I. A product in which protection against electric shock is provided not only by means of basic insulation but also through additional safety measures...

- DE VERWENDING / ANWENDUNG
Produkt für die Verwendung in Haushalten und zur allgemeinen Verwendung.
MONTAGE
Die technischen Änderungen vorbehalten. Lesen Sie vor der Montage die Anleitung. Die Montage sollte von einer Person durchgeführt werden...

- ERLÄUTERUNGEN ZU DEN VERWENDETEN MARKIERUNGEN UND SYMBOLEN
P1: Nennspannung, Frequenz.
P2: Nennleistung.
P3: Nominal-Leuchtstrahl. Der angegebene Lichtstrom bezieht sich auf die verwendete Lichtquelle (LED-Modul).

- FR
La non observation des indications du présent, ode d'emploi peut entraîner par exemple aux incendies, aux brûlures, à la commotion électrique, aux lésions physiques et aux autres dommages matériels et immatériels.
P17: Le produit est conforme à la réglementation applicable au Royaume-Uni (UK).
P18: Ce produit contient une source lumineuse d'efficacité énergétique F.

- EN
INTENDED USE / APPLICATION
Product designed for the use in households and for other similar general applications.
MOUNTING
Technical changes reserved. Read the manual before mounting. Mounting should be performed by an appropriately qualified person. Any activities to be done with disconnected power supply.

Table with 4 columns: DETECTION AREA (1-4), HOLD TIME (30s-30min), DAYLIGHT SENSOR (ON/OFF), and 2Lux/10Lux/25Lux/50Lux/Disable. Includes a diagram of the lamp's detection area.

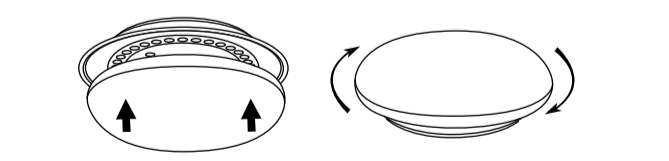
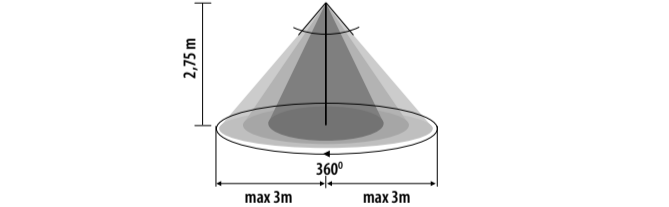

- NL
BESTEMMING / TOEPASSINGSBEBEID
Product bestemd voor gebruik in huishoudens en ruimen van algemeen gebruik.
MONTAGE
Technische veranderingen gereserveerd. Voor montage lees instructie. Montage zou kwalificeerde persoon uitvoeren.

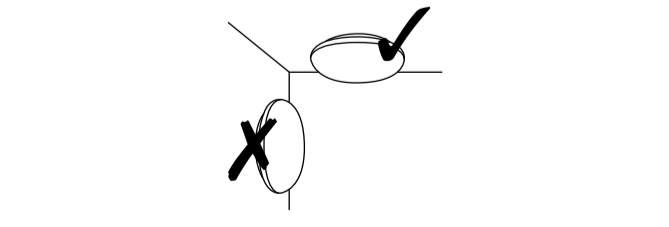

- EN
INTENDED USE / APPLICATION
Product designed for the use in households and for other similar general applications.
MOUNTING
Technical changes reserved. Read the manual before mounting. Mounting should be performed by an appropriately qualified person. Any activities to be done with disconnected power supply.

- FR
La non observation des indications du présent, ode d'emploi peut entraîner par exemple aux incendies, aux brûlures, à la commotion électrique, aux lésions physiques et aux autres dommages matériels et immatériels.
P17: Le produit est conforme à la réglementation applicable au Royaume-Uni (UK).
P18: Ce produit contient une source lumineuse d'efficacité énergétique F.

- P6: Colour temperature.
P7: Colour Rendering Index.
P8: Certificate of Conformity confirming the quality of production in accordance with approved standards on the territory of the Customs Union.
P9: Class I. A product in which protection against electric shock is provided not only by means of basic insulation but also through additional safety measures...

- IT
DISTRIBUZIONE / USO
Prodotto destinato all'uso in ambito domestico e in ambienti generali.
ASSEMBLAGGIO
Modifiche tecniche riservate. Prima di procedere con l'assemblaggio si prega di consultare le istruzioni.

- EN
INTENDED USE / APPLICATION
Product designed for the use in households and for other similar general applications.
MOUNTING
Technical changes reserved. Read the manual before mounting. Mounting should be performed by an appropriately qualified person. Any activities to be done with disconnected power supply.

- FR
La non observation des indications du présent, ode d'emploi peut entraîner par exemple aux incendies, aux brûlures, à la commotion électrique, aux lésions physiques et aux autres dommages matériels et immatériels.
P17: Le produit est conforme à la réglementation applicable au Royaume-Uni (UK).
P18: Ce produit contient une source lumineuse d'efficacité énergétique F.

- PL
PRZEZNACZENIE / ZASTOSOWANIE
Wyrob przeznaczony do stosowania w gospodarstwach domowych i ogólnego przeznaczenia.
MONTAZ
Zmiany techniczne zastrzezone. Przed przystapieniem do montazu zapoznaj się z instrukcją.

- CE
ZALAZENIA EKSPLOATACYJNE / KONSERVACIA
Konservacija
Konservacija
Konservacija
Konservacija
Konservacija

- EN
INTENDED USE / APPLICATION
Product designed for the use in households and for other similar general applications.
MOUNTING
Technical changes reserved. Read the manual before mounting. Mounting should be performed by an appropriately qualified person. Any activities to be done with disconnected power supply.

- CE
ZALAZENIA EKSPLOATACYJNE / KONSERVACIA
Konservacija
Konservacija
Konservacija
Konservacija
Konservacija

- EN
INTENDED USE / APPLICATION
Product designed for the use in households and for other similar general applications.
MOUNTING
Technical changes reserved. Read the manual before mounting. Mounting should be performed by an appropriately qualified person. Any activities to be done with disconnected power supply.

- FR
La non observation des indications du présent, ode d'emploi peut entraîner par exemple aux incendies, aux brûlures, à la commotion électrique, aux lésions physiques et aux autres dommages matériels et immatériels.
P17: Le produit est conforme à la réglementation applicable au Royaume-Uni (UK).
P18: Ce produit contient une source lumineuse d'efficacité énergétique F.

