

LED Build and controller - SETUP

1. Features

- (1). One port drives maximum 2048 pixels.
- (2). SD card supports FAT32 and FAT16 format.
- (3). Five working modes.
- (4). Switch files, adjust speed and choose loop playback or single playback by four buttons.

2. Product Display

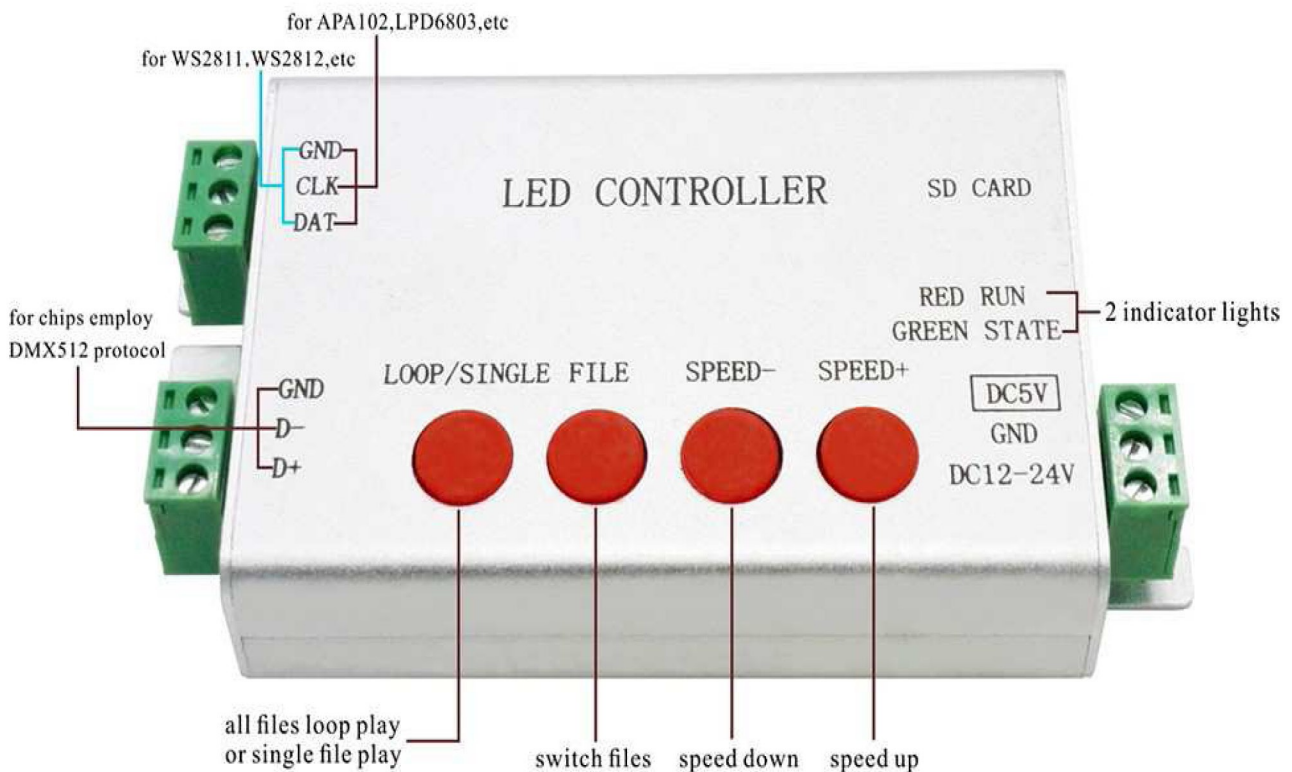

3. Supported Driver Chips

LPD6803, LPD8806, LPD1882, LPD1889, LPD6812, LPD1883, LPD1886, DMX512, HDMX, APA102, MY9221, UCS6909, UCS6912, UCS1903, UCS1909, UCS1912, UCS8904, WS2801, WS2803, WS2811, WS2812, TM1803, TM1804, TM1809, TM1812, TM1829, TA9912, TM1913, TM1914, TM1926, TM1814, INK1003, LX1003, LX2003, LX2006, TLS3001, P9813, P9816, SM16711, SM16716, LD151x, LD153x, MBI6021, MBI6023, MBI6024 and so on.

Note: H801SB supports more than the chips listed above (some chips have the same sequence diagram, for example UCS2903 has the same sequence diagram with UCS1903, H801SB supports them all).

4. SD Card Control Mode Workflow

Step 1. Program with LED Build

Place Pixels

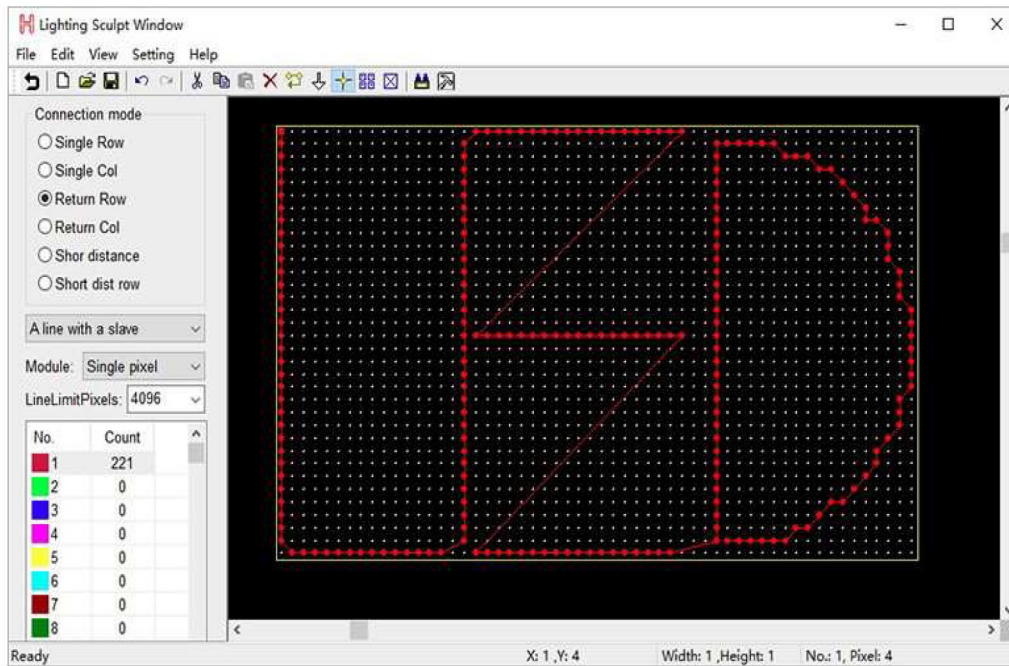

Light Setting

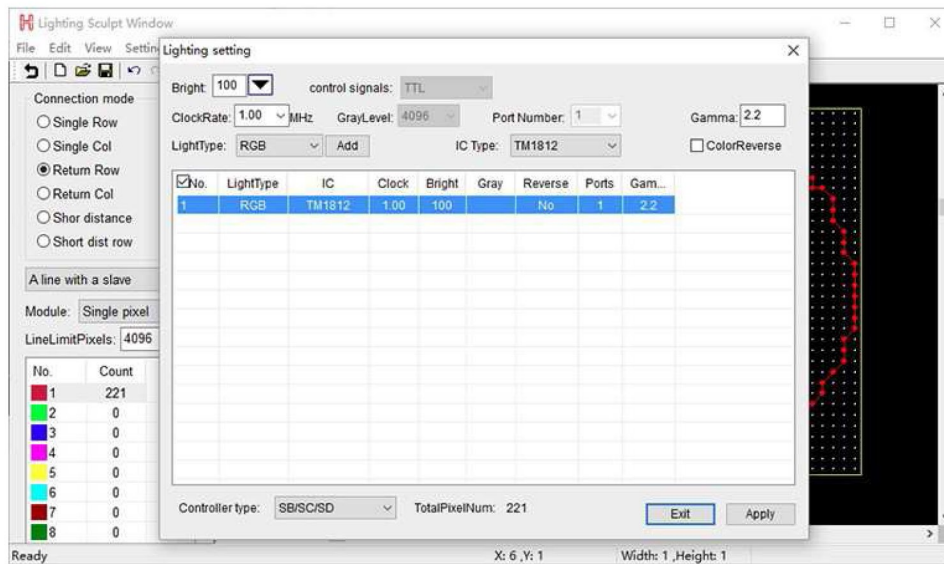

Note: lots of chips share one option

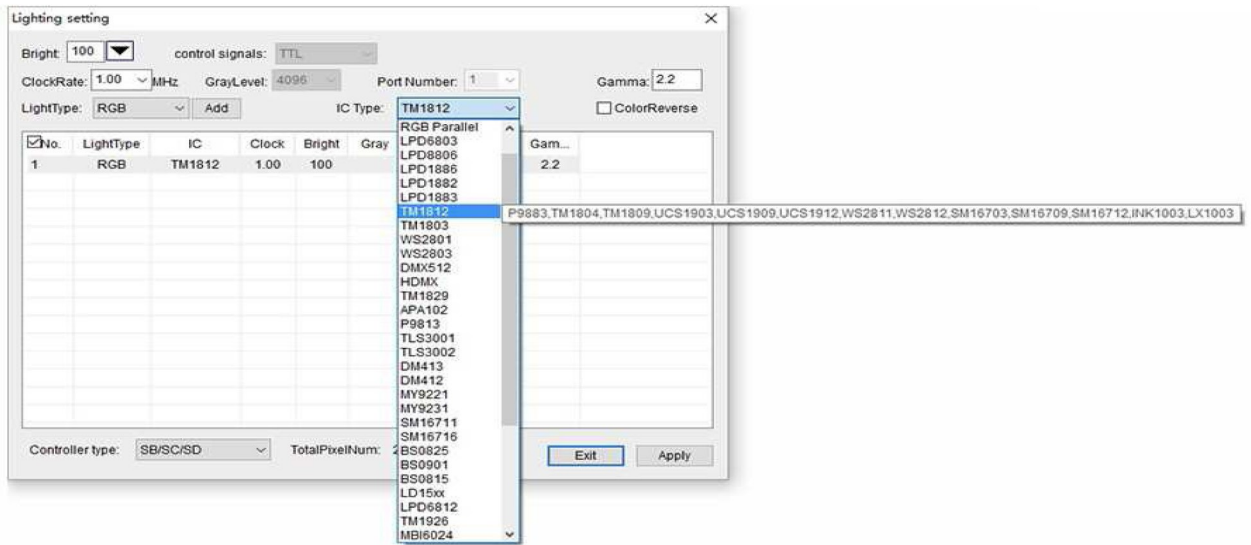

Animation Make

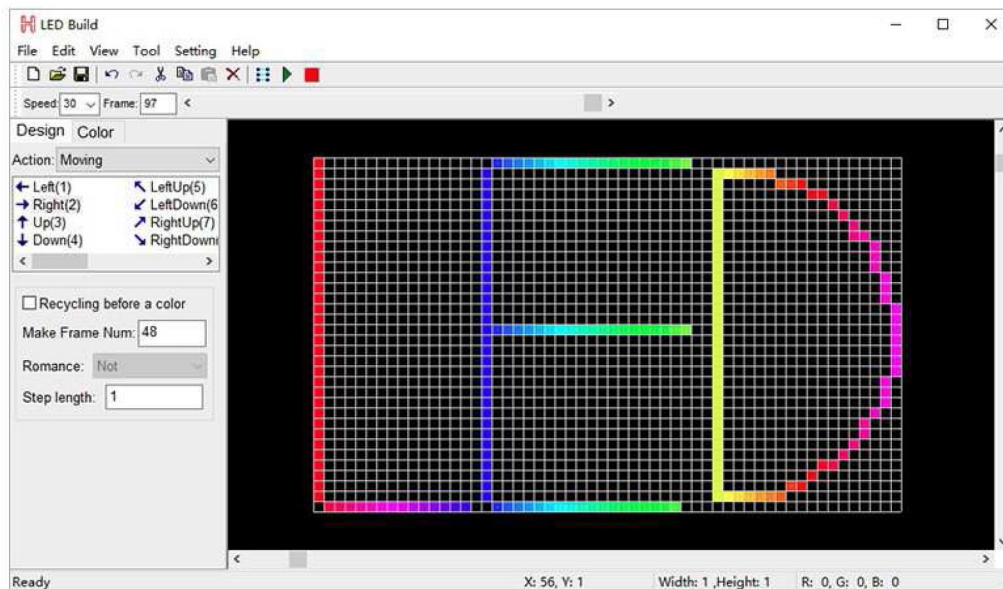

Step 2. Output Controller Data

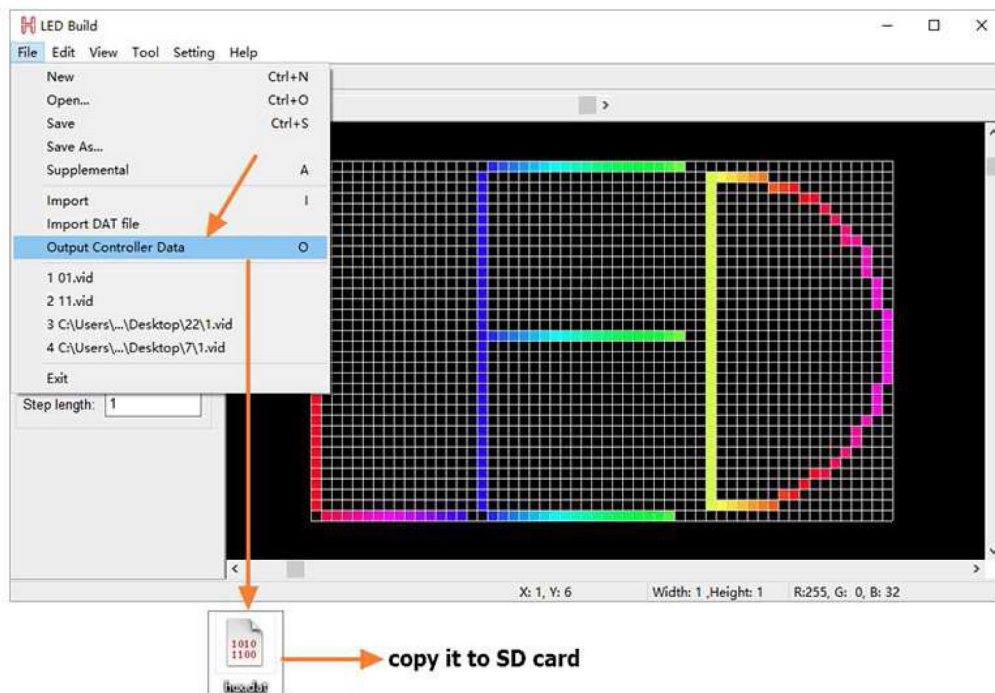

For more details of software, please refer to the video i post above.

Step 3. Connect strip to controller (the following is just for example)

Test File Download: <https://drive.google.com/open?id=0B1gzqyV6hfOgTkRHRTR2dGswT0U> (one port 200 pixels, for WS2812 and other single line chips)

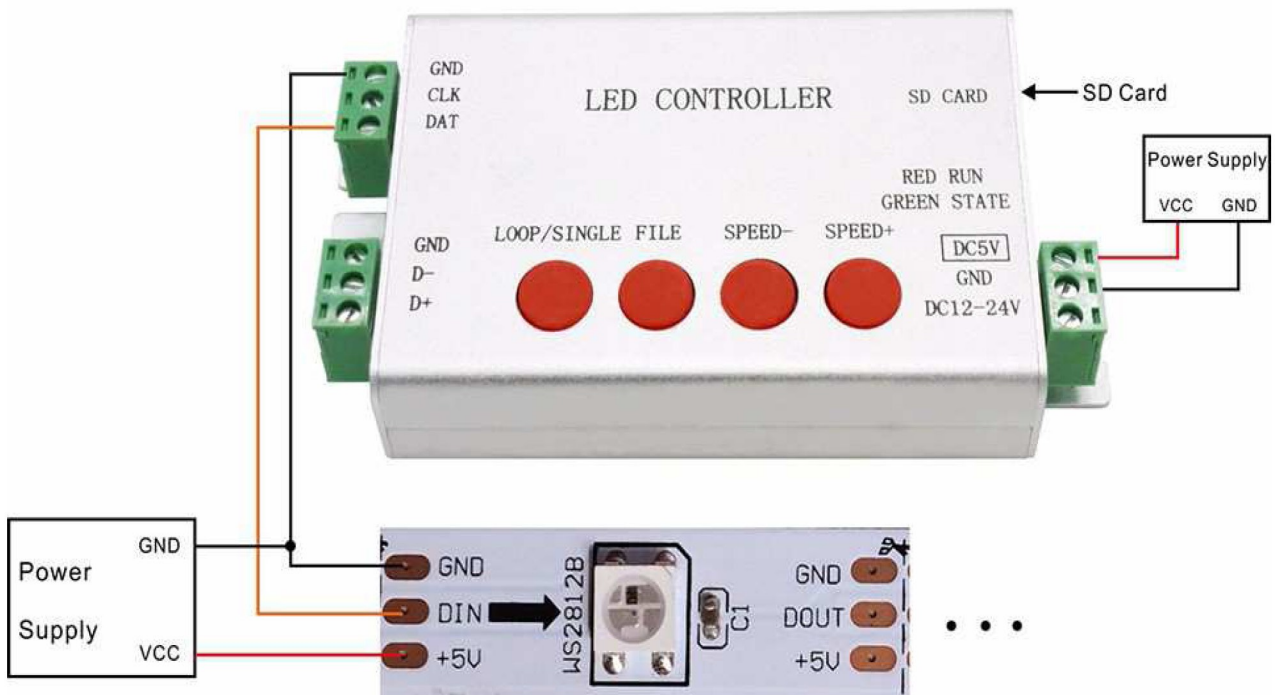

Button operation and indicator lights status

Power controller on.

With SD card inserted, green light is on and keeps still, red light is flashing.

Without SD card, green and red light are on and all keep still.

Button	Function	Indicator lights status
LOOP/SINGLE	Switch between loop playback and single playback	Loop playback: green light is on Single playback: green light is off
File	Switch files	Nothing changes
SPEED-, SPEED+	Set speed, maximum speed is 100, minimum speed is 1	Nothing changes
"LOOP/SINGLE" + "SPEED+"	Press and hold "LOOP/SINGLE" + "SPEED+", then loose them all to set address for UCS512 or TM512.	Red light is off, green light is on

5. Internal Control Mode Workflow

Step 1. Make file needed for this mode in LED Build

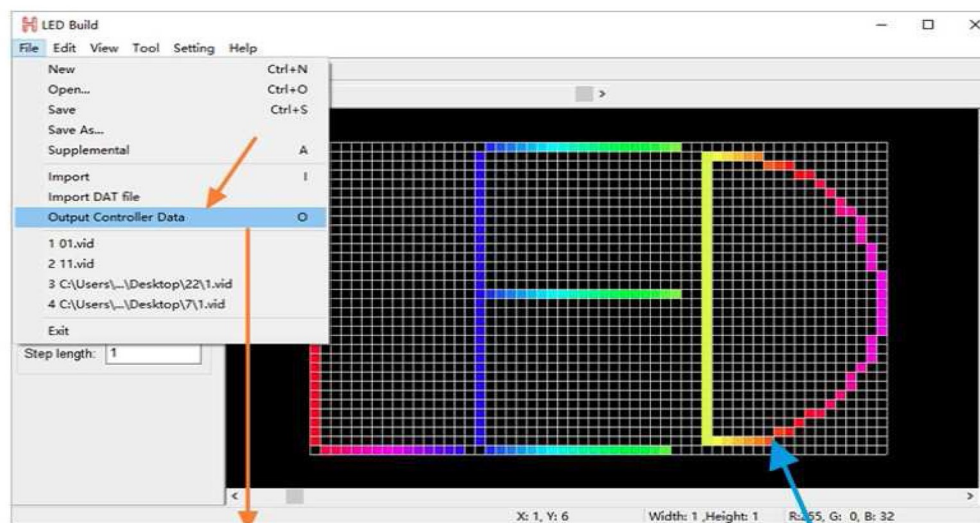
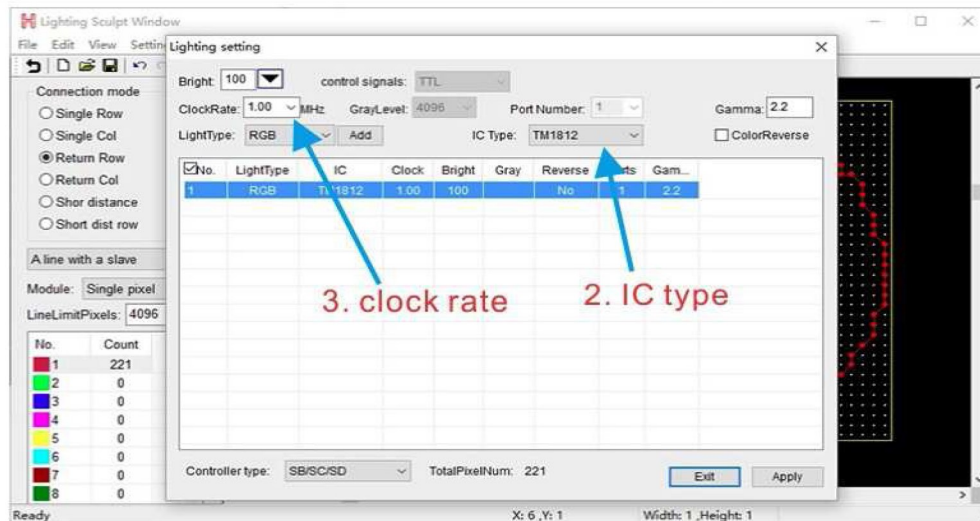
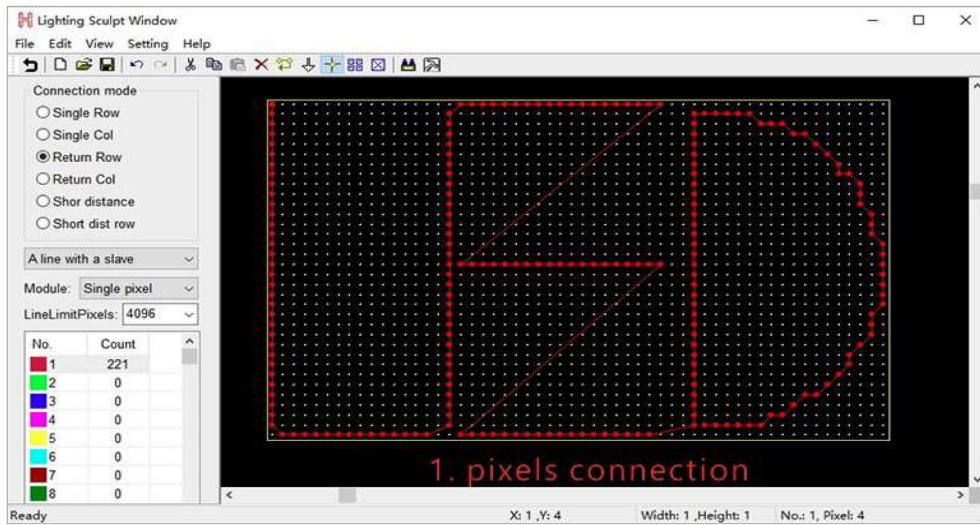

Step 2. Insert SD card, power controller on then off, take out SD card, repower controller

Step 3. Connect your strip (chip type should be the same with what you choose in step 1) to controller

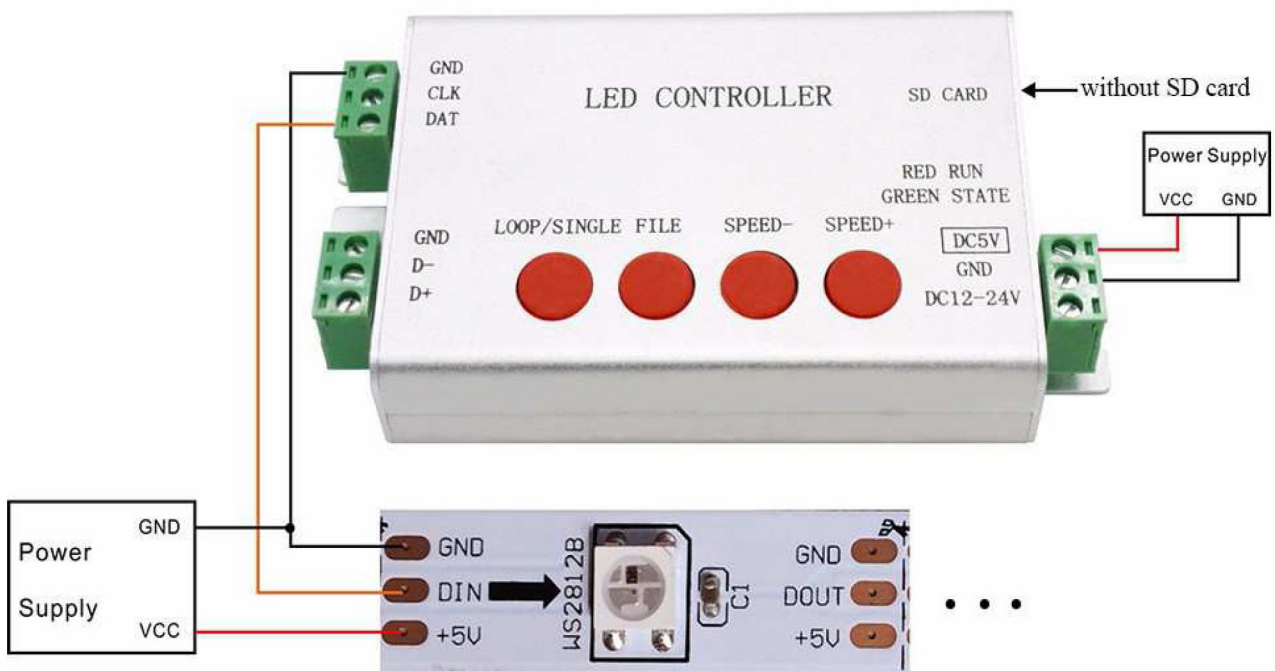

There are 18 animations built-in, use four buttons to control them.

6. Connected to DMX Console

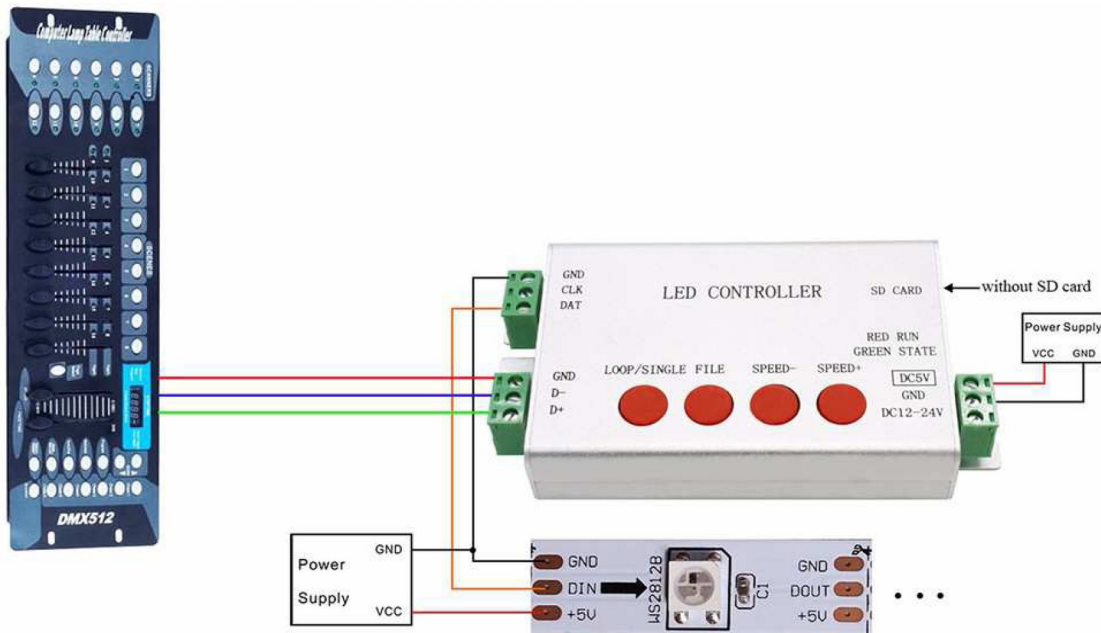

Note:

(1). In this mode, H801SB only supports the following chips

LPD6803, LPD8806, LPD1882, LPD1889, LPD1883, UCS6909, UCS6912, UCS1903, UCS1909, UCS1912, WS2801, WS2811, WS2812, TM1803, TM1804, TM1809, TM1812, TM1913, TM1914, TM1926, TM1814, INK1003, LX1003, LX2003, LX2006, TLS3001, P9813, P9816, SM16711.

(2). Before power-on, you should insert SD card with DAT file, in which includes pixels mapping, chip type, clock rate(all set in LED Build).

7. Multiple H806SBs work in synchrony for a big project

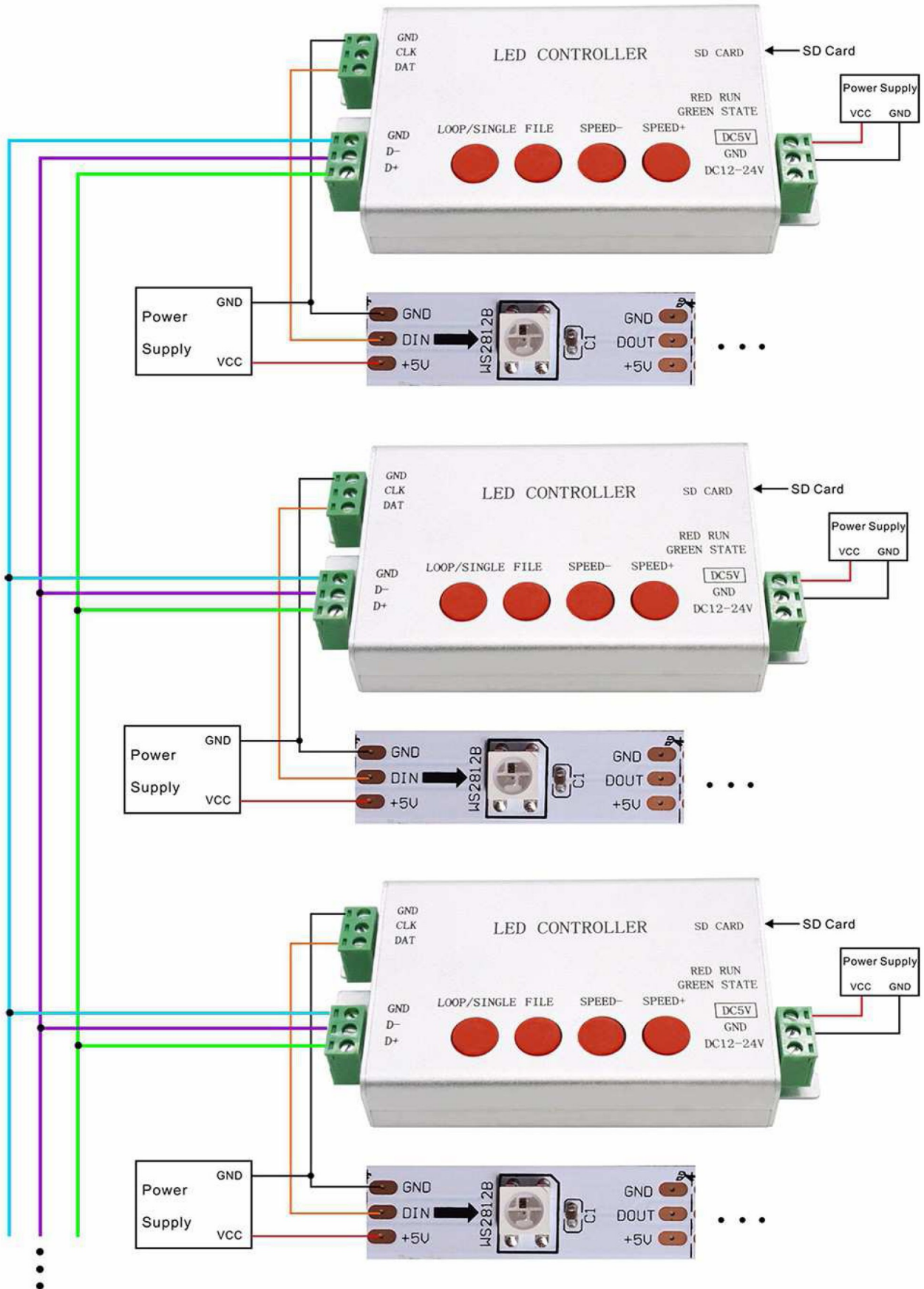

8. Set address for DMX512 chips

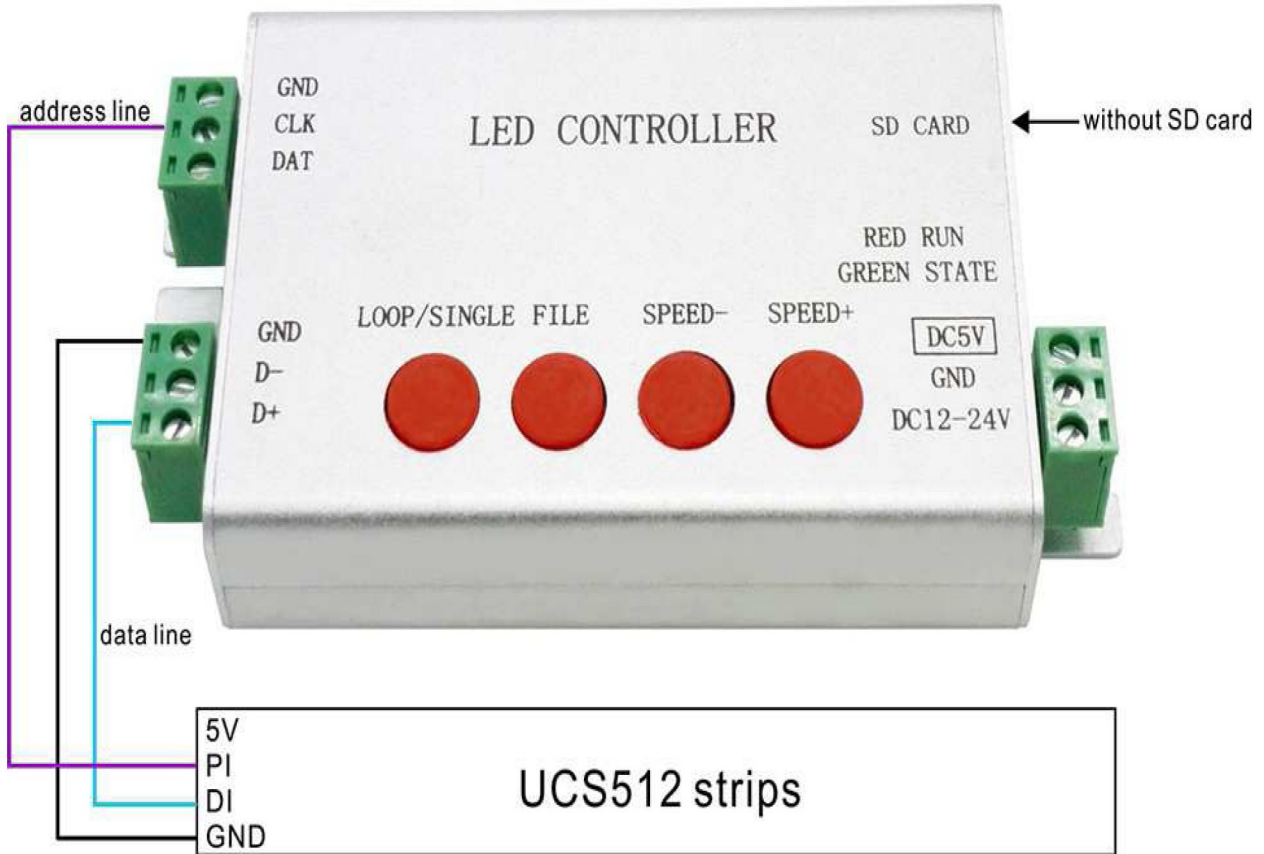



Note:

- (1). In this mode SD card is not necessary.
- (2). Press "LOOP/SINGLE" + "SPEED+", then loose them all, lights will turn white then green, which means address is successful.
- (3). Only after lights are repowered is address updated.
- (4). can address for maximum 1024 pixels.