

Datový list | Objednací číslo: 221-510

Upevňovací adaptéry; Řada 221 – 6 mm²; Pro montáž na lištu DIN 35 / šroubovou montáž; Oranžová

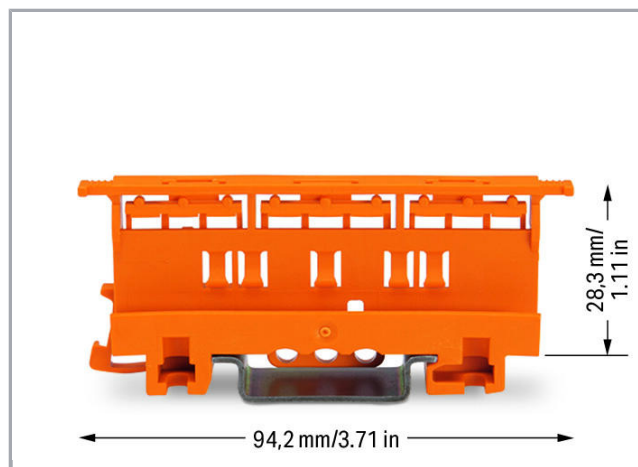

www.wago.com/221-510

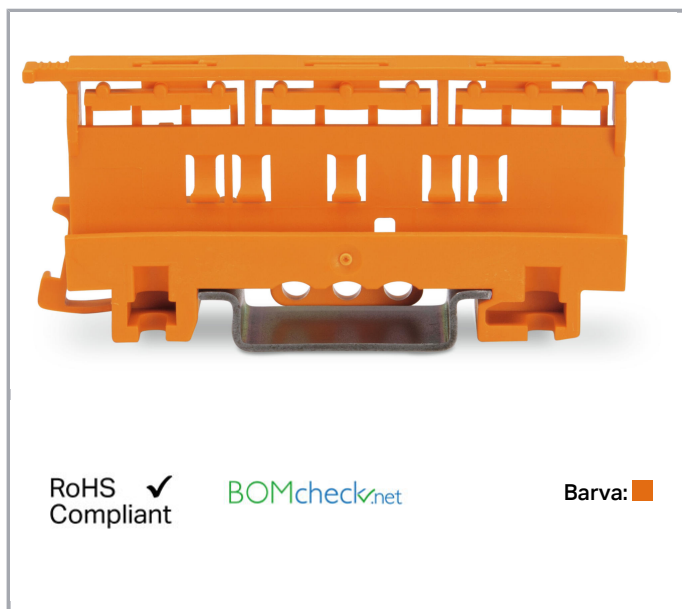

Data

Geometrické údaje

Šířka	19,3 mm / 0.76 inch
Výška od horní hrany lišty DIN 35	28,3 mm / 1.114 inch
Hloubka	94,2 mm / 3.709 inch

Údaje o materiálu

barva	Oranžová
Izolační materiál	Polyamid 66 (PA 66)
Třída hořlavosti dle UL94	V0
Hmotnost	11.89 g

Obchodní údaje

Druh balení	BOX
Country of origin	CN
GTIN	4055143736695
Customs Tariff No.	39269097900

Kompatibilní produkty

Marking accessories



Obj. č.: 210-833

Popisovací páska; Na cívce; Šířka 6 mm; Bez potisku; Samolepicí; Bílá

www.wago.com/210-833

Mounting adapter



Obj. č.: 222-505

Podložka pro odlehčení tahu; Pro upevňovací adaptér; Řada 221 nebo 222, možnost naklapnutí

www.wago.com/222-505



Obj. č.: 222-510

Univerzální úhlový adaptér; V kombinaci s upevňovacím adaptérem; 221-500 nebo 222-500; K montáži na lištu DIN 35; Šedá

www.wago.com/222-510

Ke stažení

Documentation

Additional Information

Technical explanations

03-Apr-2019

pdf
2,1 MB

Stáhnout

CAD/CAE-Data

CAD data

2D/3D Models 221-510

URL

Stáhnout

Handling Instructions

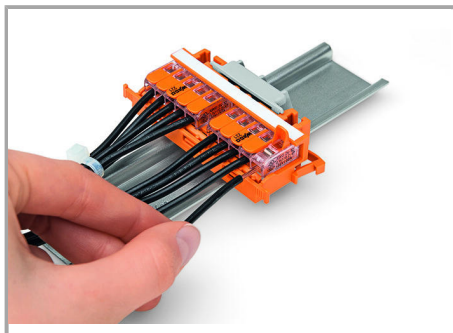

CAGE CLAMP® connection:

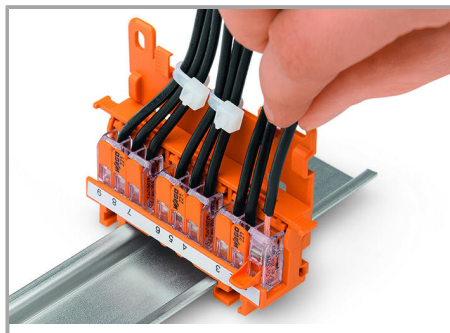

Removing a conductor.

Conductor termination with connectors fitted in a mounting carrier

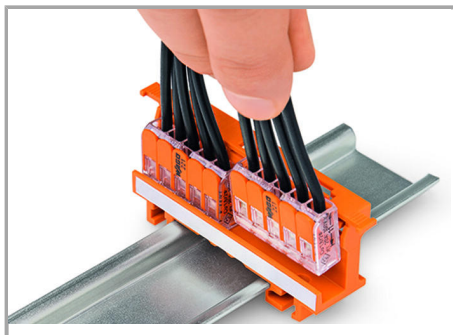

Inserting a connector into the mounting carrier.



Inserting a connector into the mounting carrier.

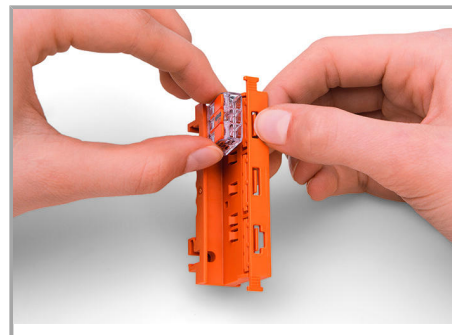

Removing a connector from the mounting carrier.

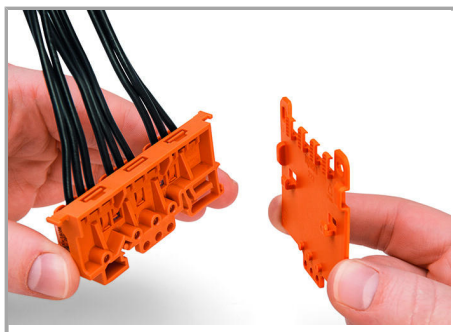

Securing a strain relief plate (222-505) to the mounting carrier. Změny vyhrazeny.

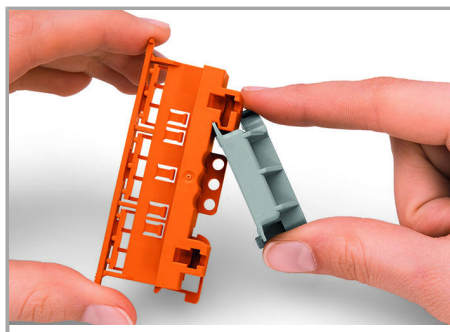

Snapping the angled DIN-rail adapter (222-510) onto the mounting carrier.

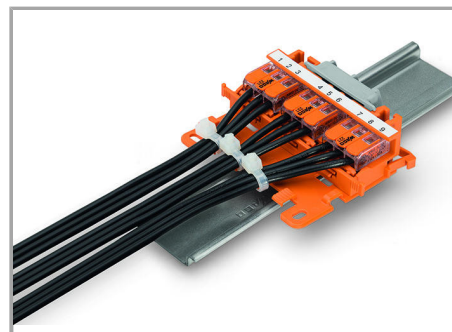

Horizontal mounting on DIN-35 rail using an angled DIN-rail adapter.

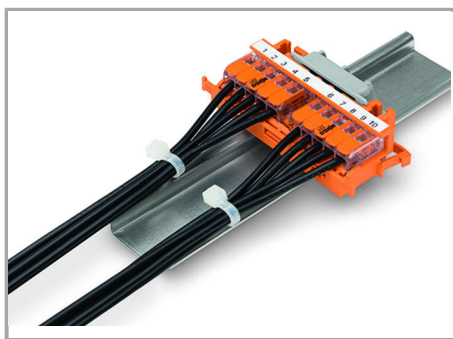

Horizontal mounting on DIN-35 rail using an angled DIN-rail adapter.

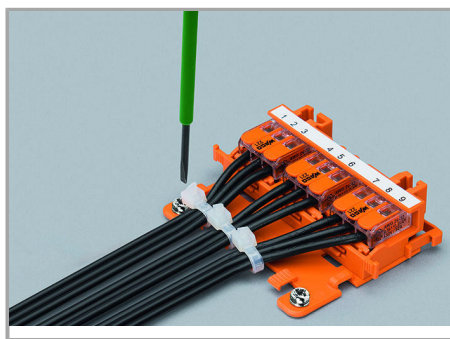

Horizontal screw mounting with strain relief plate on a flat surface

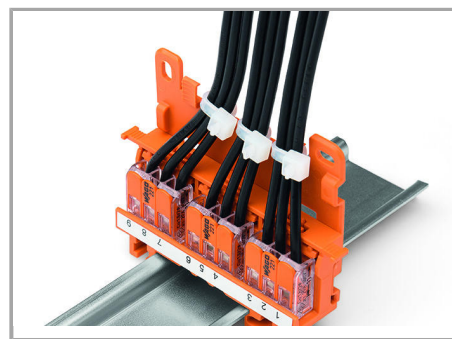

Vertical mounting with strain relief plate on DIN-35 rail.

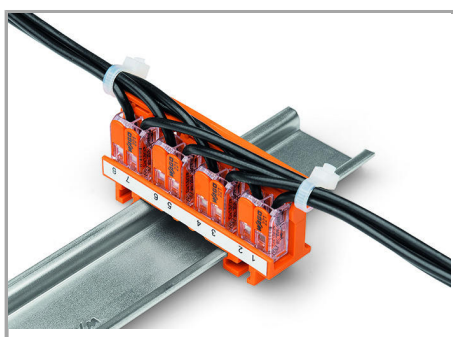

Strain relief via cable ties on the mounting carrier (transverse to the connectors' wiring direction) – clamping units labeled via marking strips (210-334).

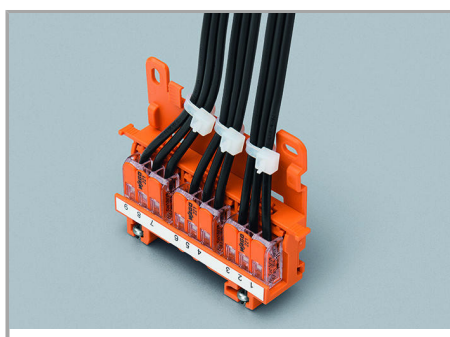

Vertical screw mounting with strain relief plate on a flat surface.



Mounting carrier on a DIN-35 rail

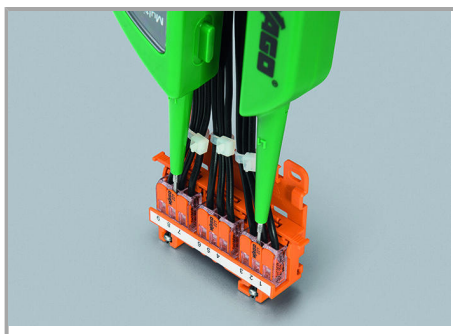

Testing connectors via test slots on top of the carrier.

Změny vyhrazeny.

WAGO Elektro spol. sr. o.
Rozvodova 1116/36
143 00 Praha 12 - Modřany
Tel.: +420 261 090 143
Email: info.cz@wago.com, wago-cz@wago.com

Máte otázky ohledně našich produktů?
Kdykoli nám zavolejte na číslo +420 261 090 143.