

# Datový list | Objednací číslo: 789-128

Svorka na desky plošných spojů; 2,5 mm<sup>2</sup>; Rozteč 5 mm; 2pól.; CAGE CLAMP®; 2,50 mm2; Šedá

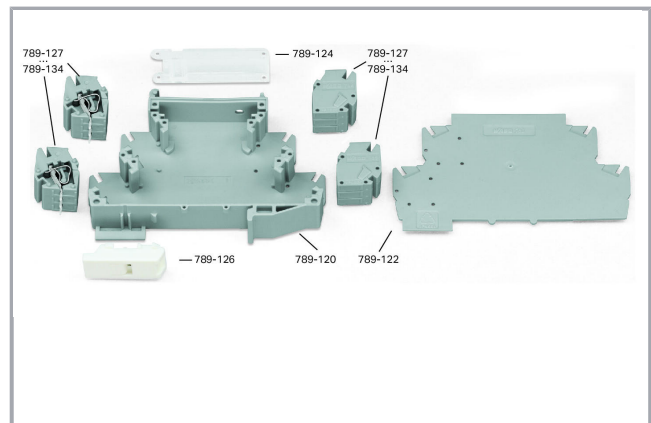

[www.wago.com/789-128](http://www.wago.com/789-128)

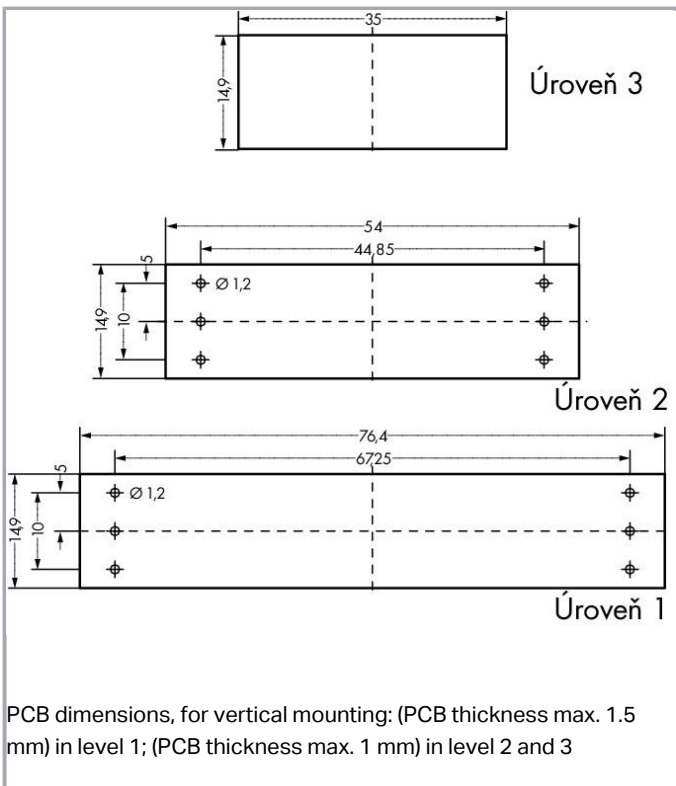
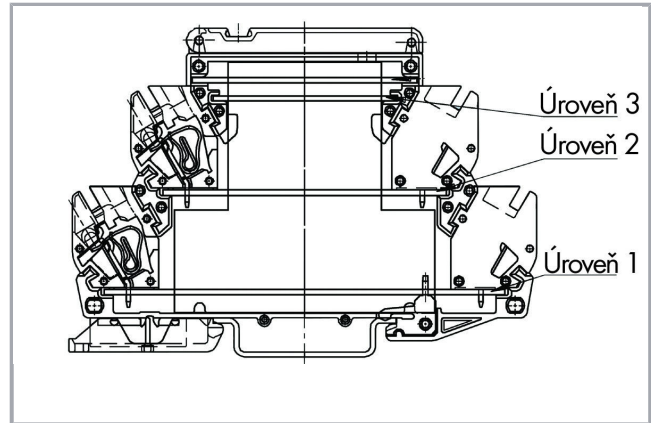
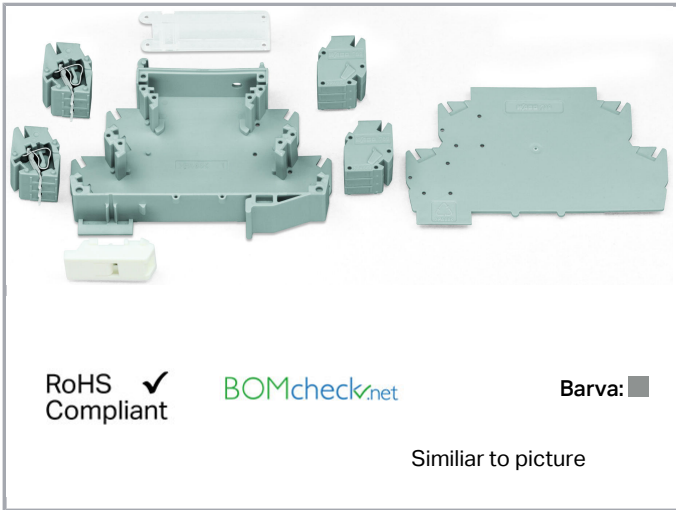

## Popis položky

Universal modular component housing, as DIN-rail-mount enclosure – terminal block, 3-pole: COC\*

(\*C = with clamping spring; O = without clamping spring; enclosure open on the right side)

**Data****Údaje o připojení**

Počet pólů	3
Connections (number)	2

**Mechanické parametry**

Provedení pouzdra	Pouzdro k montáži na DIN lištu
Suitable	For 789-120

**Údaje o materiálu**

barva	Šedá
Požární zatížení	0.067 MJ
Hmotnost	3.49

**Obchodní údaje**

Druh balení	BOX
Country of origin	DE
GTIN	4044918611749
Customs Tariff No.	85369010000

**Kompatibilní produkty****General accessories**

**Obj. č.: 789-120**  
Pouzdro 55 mm; Šedá

[www.wago.com/789-120](http://www.wago.com/789-120)

**ferrule**

**Obj. č.: 216-241**  
Ferrule; Sleeve for 0.5 mm<sup>2</sup> / 20 AWG; insulated; electro-tin plated; electrolytic copper; gastight crimped; acc. to DIN 46228, Part 4/09.90; white

[www.wago.com/216-241](http://www.wago.com/216-241)



**Obj. č.: 216-242**  
Ferrule; Sleeve for 0.75 mm<sup>2</sup> / 18 AWG; insulated; electro-tin plated; electrolytic copper; gastight crimped; acc. to DIN 46228, Part 4/09.90; gray

[www.wago.com/216-242](http://www.wago.com/216-242)



**Obj. č.: 216-243**  
Dutinka; Objímka na 1 mm<sup>2</sup> / AWG 18; S plastovým límcem; Galvanicky pocínováno; Elektrolytická měď; Plynotěsně osazena; Dle DIN 46228, část 4/09.90; Červená

[www.wago.com/216-243](http://www.wago.com/216-243)



**Obj. č.: 216-244**  
Dutinka; Objímka na 1,5 mm<sup>2</sup> / AWG 16; S plastovým límcem; Galvanicky pocínováno; Elektrolytická měď; Plynotěsně osazena; Dle DIN 46228, část 4/09.90; Černá

[www.wago.com/216-244](http://www.wago.com/216-244)

**Ke stažení****Documentation**



#### Additional Information

Disposal; Electrical and electronic equipment, Packaging	V 1.0.0	pdf 265,8 kB	Stáhnout
--	---------	-----------------	----------

---

#### CAD/CAE-Data

##### CAD data

2D/3D Models 789-128	URL	Stáhnout
----------------------	-----	----------

---

##### CAE data

WSCAD Universe 789-128	Stáhnout
------------------------	----------

---

#### Handling Instructions

Změny vyhrazeny.

---

WAGO Elektro spol. sr. o.  
Rozvodova 1116/36  
143 00 Praha 12 - Modřany  
Tel.: +420 261 090 143  
Email: [info.cz@wago.com](mailto:info.cz@wago.com), [wago-cz@wago.com](mailto:wago-cz@wago.com)

Máte otázky ohledně našich produktů?  
Kdykoli nám zavolejte na číslo +420 261 090 143.