	2x 1,5mm ² 2x 1,5 mm ²	- 5°C ... +50°C от - 5 °С до +50 °С	- 10°C ... +60°C от - 10 °С до +60 °С
		2x 1,5mm ² 2x 1,5 mm ²		

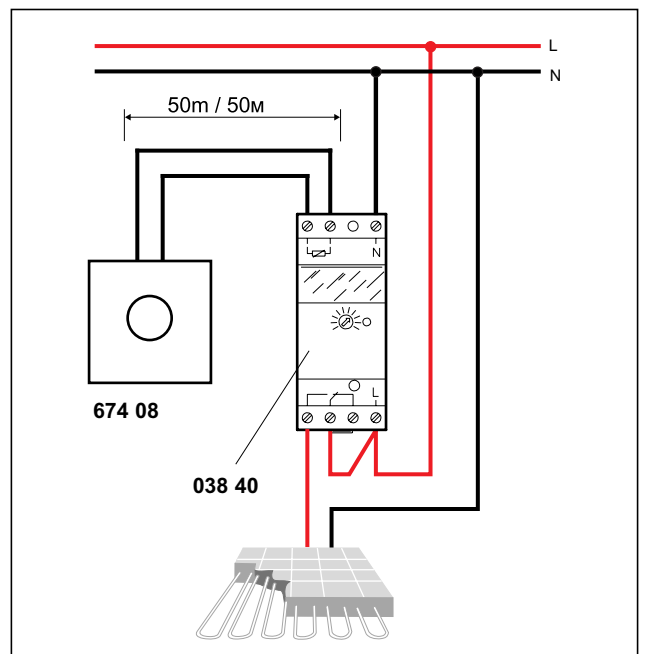

- **Important** : La régulation de température n'est effective que deux heures après la mise sous tension (période de stabilisation thermique de l'électronique).
- **Belanrijk** : De temperatuurregulatie is pas effectief 2 uur na het onder spanning plaatsen. (Thermische stabilisatieperiode van de electronica).
- **Important** : Temperature regulation is only effective two hours after the device has been switched on. (Thermal stabilisation period for the electronics).
- **Hinweis** : Die Temperaturregelung funktioniert erst 2h nach Inbetriebnahme richtig (Dauer der thermischen Stabilisierung).
- **Importante**: La regulación de la temperatura es únicamente efectiva 2 horas después de haber conectado el dispositivo (período de estabilización térmica del sistema electrónico).
- **Примечание**: Регулировка температуры начинает функционировать правильно только через два часа после включения питания (время стабилизации температуры электронного оборудования).
- **Önemli**: Sıcaklık ayarlama ancak cihaz açıldıktan iki saat sonra etkili olabilir. (Elektronik cihazların stabil duruma gelme periyodu).

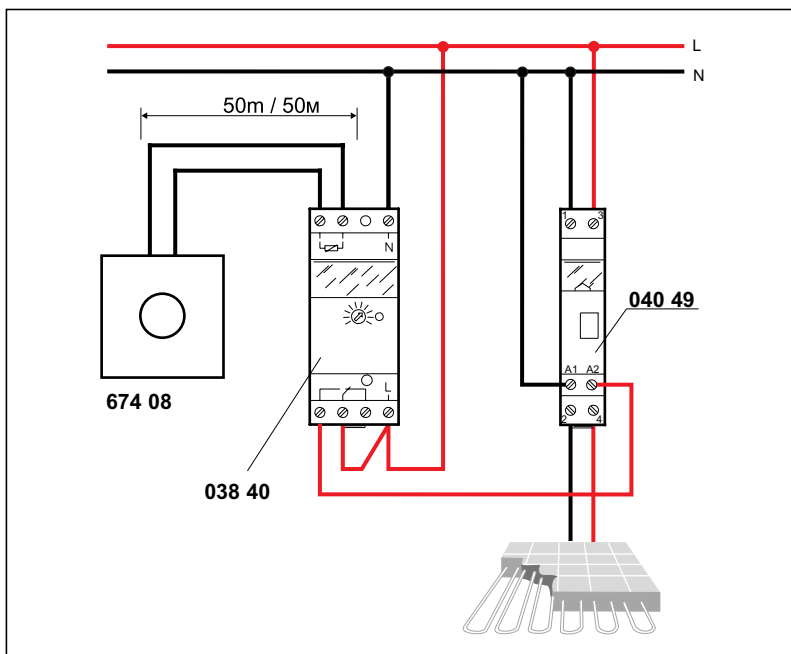

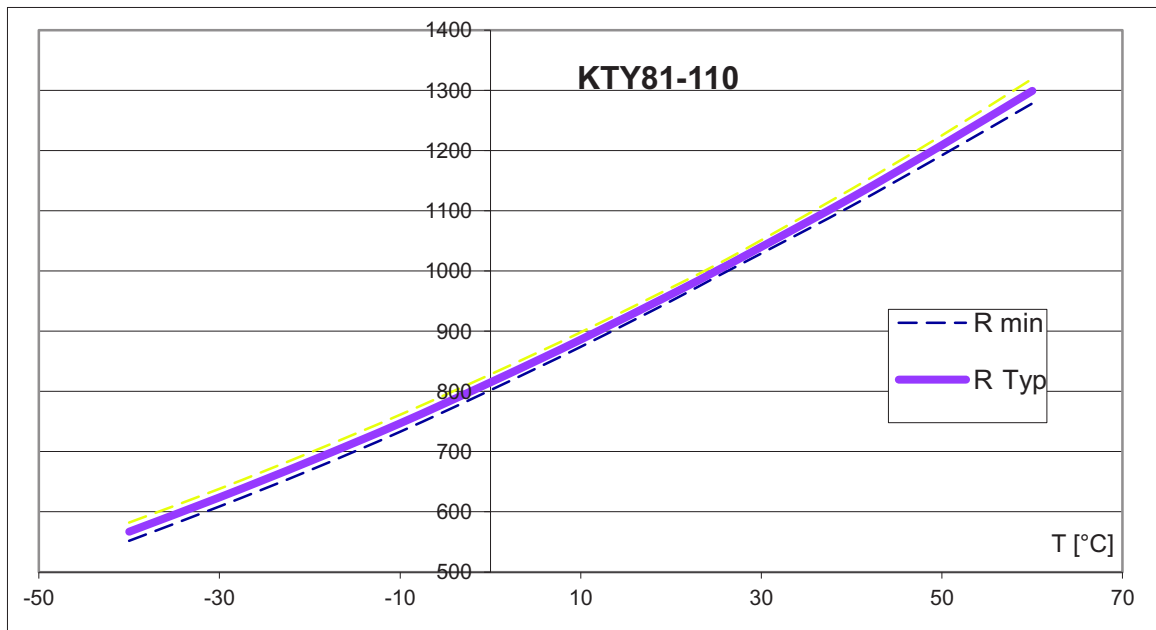

T	R min	R Typ	R max
-40	552	567	582
-30	609	624	638
-20	669	684	698
-10	733	747	761
0	802	815	828
10	874	886	898
20	950	961	972
25	990	1000	1010
30	1029	1040	1051
40	1108	1122	1136
50	1192	1209	1225
60	1278	1299	1319