

CONTENT	PAGE
■ 1. Use	2
1.1 Products and Function Overview	2
■ 2. Technical features	2
2.1 Electrical features	2
2.2 Operation/display	2
2.3 Climatic features	2
■ 3. Dimensions	3
■ 4. Connection	3
■ 5. Standards and approvals	3
■ 6. COMMUNICATION OBJECTS	3
6.1 Project Design and Application	3
6.1.1 General Introduction	3
6.1.2 System Mode and Button Operation Introduction	3
6.1.3 Coil System	3
6.1.4 Fan System	4
6.1.5 Room Temperature Control Mode and Setting Temperature Adjustment	4
6.1.6 Control Types	4
6.1.7 Type of control	5
6.2 Description of communication objects	5
6.3 Outline	7
6.4 General Parameter setting window "General"	7
6.5 Parameter window: "Temperature setting"	8
6.6 Parameter window "Setpoints"	9
6.7 Parameter setting interface "Controller"	10
6.8 Parameter setting interface Fan"	11
6.9 Parameter setting interface "heating valve" and "cooling valve" (continued)	13
6.10 Parameter settings interface "Window contact"	14
6.11 Parameter settings interface "Temperature monitoring"	14
6.12 Parameter setting window "Scene"	15
6.13 External control parameter setting interface	16

1. USE

The user manual describes detailed technical information of Fan Coil Controller, including installation and programming; as well it shows usage integrating with application examples. To achieve convenient installation in distribution box, Fan Coil Controller is designed to a modular installation device, and be installed on 35mm DIN Rail according to EN 60 715. It adopts screw terminal to achieve electrical connection. The connection to EIB/KNX BUS is established via EIB connecting terminal. Input requires connecting 230V AC operating voltage for Fan Coil Controller.

Fan Coil Controller can be connected to other EIB/KNX devices to make up the system via EIB/KNX BUS.

Engineering Tools Software (ETS) can be used to use and operate the system.

1.1 Products and Function Overview

The Fan Coil Controller can work after connecting 230V AC voltage input and power supply directly, without extra power. The parts of valve need voltage input of 75V AC-230V AC according to demands. The configuration of physical address and setting of parameters can both be achieved by using VD4 database in ETS (ETS3 and above) .

Fan Coil Controller outputs heating and cooling according to temperature's setting, and the max. load current of valve output is 2A. There are 3 levels of fan speed, and max. load current of each level reaches 6A. Both valve of heating and refrigeration and fan speed can be opened or closed by manual button, and their status is shown by LED lighting.

The functions of Fan Coil Controller are shown as follows:

- Output heating and cooling according to temperature's setting
- Output modes of Standby, Comfort, Night and Protection according to user's demands.
- Control fan speed in 3 gears (High, Medium, and Low) manually or automatically.
- Control the raise/lower valves and ordinary switching valves intelligently and manually.
- Achieve continuous or PWM output control by valves by PI controlling value.
- Report local fan speed and valve's status.
- Obtain temperature data collection from local or BUS, and achieve the monitoring function to actual temperature and frost temperature.
- Own the function of modes of specific scene and Adjustable speed.
- Detect shutter's on-off status or binary input.
- Achieve the controlling by external controller (eg. Temperature Control Panel)

2. TECHNICAL FEATURES

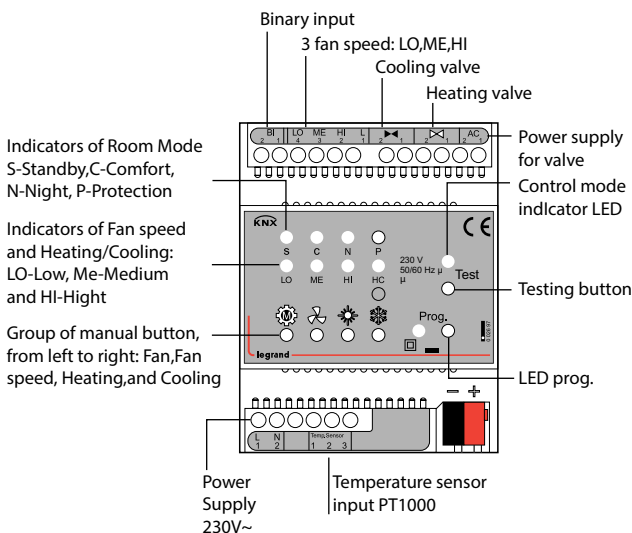

2. TECHNICAL FEATURES (continued)

2.1 Eelectrical features

Power Supply

- Operating Voltage: 230 V AC +/-10% (50/60Hz)
- Total Power Consumption: 1.4W
- Input Voltage: 21-30DC, via EIB/KNX BUS
- Current via KNX: <12mA
- Power Consumption via KNX: <360mW

Control of Heating and Refrigeration

- 2 folds Valve Control: Continuous motor lift valves and thermal valve can be connected. One fold for heating, the other for refrigeration.
- Nominal Voltage: 75V~256V AC (220VAC or 110VAC Motor)
- Nominal Current: 2A
- Cable Length Max. 20m

Fan Control

- 1 fold Fan 3 fan speeds
- Nominal Voltage 230 V AC - 50/60Hz
- Nominal Current 6A

Note:

In the case that above 3folds are used as independent switching, the max. current of each fold 6A, and the total of 3 folds cannot exceed 13A.

Note: Binary Input

- 1 binary input check: For shutter's on/off status and binary input
- Nominal Voltage: 9V~265V AC/DC
- Cable Length Max. 100m (transversal surface: 1.5mm²)

2.2 Operation/display

Button and Indicator LED

Button & Indicator LED Group:

- Button is used for operation, while Indicator Function LED for indicating.
- Fan Gears: 1 button and 3 green LED
- Room Modes: 1 button and 4 red LED
- Heating/Cooling: 2button and 1 red & blue LED
- Programming: 1button and 1 red & green LED

Pls refer to 2 for location of Button and Indicator LED, and 3.2 for operation introduction

2.3 Climatic features

Ambient temperature range

- Scope Operation: - 5°C ... + 45°C
- Storage: - 25°C ... + 55°C
- Transport: - 25°C ... + 70°C

Tem. Measurement

- Three-wire system PT100 Tem. : Sensor It is used to detect tem.
- Measuring Scope of Tem. :- 45°C ... + 80°C
- Cable Length: 2m

Weight

0.3kg

3. DIMENSIONS

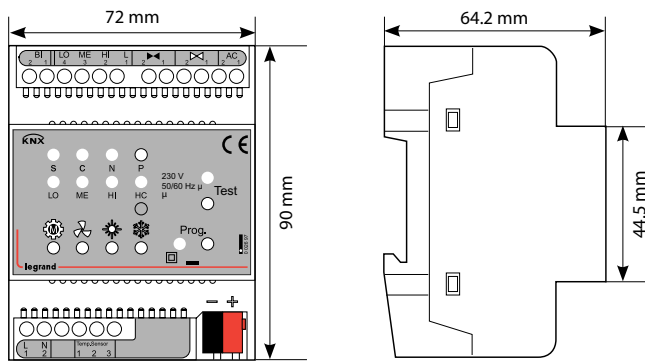

4. CONNECTION

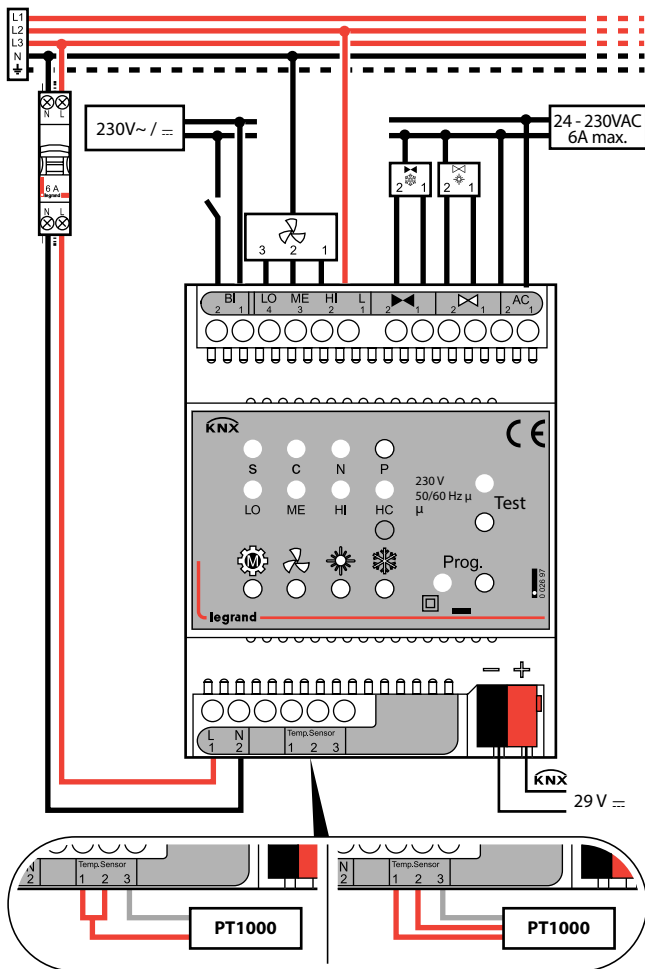

5. STANDARDS AND APPROVALS

Marking

KNX, CE

Certification

KNX approved

CE certified

Note:

All technical information is available at



6. COMMUNICATION OBJECTS

6.1 Project Design and Application

6.1.1 General Introduction

Application Program	Max. number of Communication Objects	Max. number of Group Address	Max. number of Association
Fan coil Controller	38	50	50

Fan Coil Controller controls Fan's fan speed and Valve's opening degree intelligently by PI Algorithm, and achieve heating/cooling to make rooms comfortable through comparison between setting temperature and actual temperature. Fan Coil Controller contains 1 fold temperature data collection, 1 fold binary input, 1 fold Fan control and 2 folds Valve control.

6.1.2 System Mode and Button Operation Introduction

Fan Coil Controller has 3 modes: Automatic Control Mode, Manual Control Mode, and Testing Control Mode.

Automatic Control Mode. When testing/auto indicator light is off, the mode is automatic control. It controls Fan Coil's output. In this mode, it can be toggled to testing or manual control mode, and room modes can also be switched.

Manual Control Mode. When testing/auto indicator light is on, the mode is manual control. It enters manual mode via calling scene (Object 12) or control fan speed manually, and exits the mode via setting Object 16 to 1. Manual control mode refers to adjusting Fan's fan speed via KNX telegram (Note: this mode is for Fan only, and Valve). Under this mode, only manual control mode can be switched to, while the room modes can be changed by using their buttons.

Testing Control Mode When testing/auto indicator light is flashing, the mode is testing control. It enters or quits testing mode via pressing switch buttons of testing/ auto for 2s. In this mode, it can control output of valves via heating button and cooling button. Besides on/off, it can control pause function of local raise/lower valve; the valve would stop when heating or cooling button is pressed for 2s, and the heating/cooling indicator would flash. It exits pause function when the button is pressed momentarily. Fan speed can be adjusted via fan-speed button; its short press changes fanspeed gear, long press opens/ closes the gear, and the corresponding indicators would be on or off. In this mode, room mode cannot be change unless to change control mode to auto mode.

6.1.3 Coil System

Fan Coil Controller can be designed as 2-pipe, 3-pipe, or 4-pipe version, according to hot and cold water's circulation loops.

The 2-pipe version consists of a single water circulation loop for both hot and cold water. It is achieved only by connecting one fold valve to control flow of hot and cold water, and the default connecting is heating end. In lots of practical application, only cooling is carried out via a 2-pipe fan coil, and heating is implemented by other conventional heaters.

The 3-pipe and 4-pipe versions are quite similar to each other. For 3-pipe version, the hot and cold water have separate inlet, while they share one outlet. The 4-pipe version has separate water circulation loops for both hot and cold water. For both 3-pipe and 4-pipe, hot and cold water's flow can be controlled by connecting to Fan Coil Controller's control terminal of heating and cooling valve.

Valve has two type: Raise/ lower valve and Thermal valve. Raise/ lower valve control valve's opening according to its run time, to achieve status of on, off and pause. It is 3-wire system, shown as wiring diagram. Thermal valve is usually divided to normally open type and normally closed type, and has only two statuses: on/off. It is 2-wire system, and one for valve's open, the other for null line of valve power supply.

6. PARAMETERS AND COMMUNICATION OBJECTS (continued)**■ 6.1 Project Design and Application (continued)****6.1.4 Fan System**

Fan system can control local Fan, as well external Fan, and it is achieved via parameter setting of "Type of fan"

Fan can be controlled both automatically and manually. Auto control is Fan Coil's control according to algorithm output. Manual control is used to adjust current fan speed according to KNX telegram. Under manual control, Fan cannot be controlled by Fan Coil Controller, unless the mode is auto control.

Auto-control Fan adopts stepping sequence, that is, the fan speed can be adjusted step by step only, but not phase step. For example, to change current gear 0 to 3, the operation order is 1->2->3, and between each two gears, it would stay at least 2mins due to the parameter "Minimum delay at fan speed". The limitation is un available when it is manual mode or testing mode.

6.1.5 Room Temperature Control Mode and Setting Temperature Adjustment**Room Temperature Control Mode**

Room temperature control has 4 modes: comfort mode, standby mode, night mode, and protection mode, and it is used to adjust rooms' setting temperature, and it can be switched via KNX BUS or room mode button.

Via KNX BUS, to select a 1byte communication object or three 1bit objects can help to switch room modes.

When selecting three 1bit objects as above-mentioned, the objects have priority as follows: protection mode > comfort mode > night mode > standby mode. Writing "1" on the relevant object enables room mode, and writing "0" disable it. When lower priority would replace the higher priority, close the latter first. When object 9, object 10 and object 11 are "0", the mode is lowest priority – standby mode.

When selecting a 1byte to switch to room mode, value 0: stay; value 1-4 represent comfort mode, standby mode, night mode, and protection mode respectively; value 5-255, invalid.

Setpoint values

Setpoint value is configured in the parameter window "Setpoints".

Setpoint temperature of actual output can be calculated according to following:

Comfort mode:

Heating: Setpoint temperature = Base setpoint temperature + Setpoint adjustment

Cooling: Setpoint temperature = Base setpoint temperature + Setpoint adjustment + Insensitive zone + external temperature correction (Pls refer to "External temperature" in the parameter window "Temperature setting " under cooling control)

Standby mode:

Heating: Setpoint temperature = Base setpoint temperature – Reduces heating in standby mode + Setpoint adjustment;

Cooling: Setpoint temperature = Base setpoint temperature + Increased cooling in standby mode + Setpoint adjustment

Night mode :

Heating: Setpoint temperature = Base setpoint temperature –Reduces heating in night mode + Setpoint adjustment;

Cooling: Setpoint temperature = Base setpoint temperature + Increased cooling in night mode + Setpoint adjustment

6. PARAMETERS AND COMMUNICATION OBJECTS (continued)**■ 6.1 Project Design and Application (continued)****6.1.5 Room Temperature Control Mode and Setting Temperature Adjustment (continued)****Protection mode:**

Heating: Setpoint temperature = Threshold value for heat protection

Cooling: Setpoint temperature = Threshold value for frost protection

Note:

When user chooses "Heating and cooling " of "Controller mode in Heating/Cooling" in the parameter window "General", auto control to toggle heating and cooling is related to setting temperature in comfort mode only, that is, the comparison between setting temperature and actual temperature generate heating or cooling.

6.1.6 Control Types**Continuous-action Control**

With continuous-action control, a control value is calculated from the actual temperature and the setpoint temperature and then used for the optimum regulation of the temperature. For example, if control value is 50% of max value, the valve is moved to position of be 50% ; If the value is the max, the valve can thereby be fully opened. Continuous control can achieve function of "open", "close" and "pause". Pls refer to following picture for specific actions.

With continuous-action control, the most accurate regulation of the temperature can be achieved without considerable overshoots. Meanwhile, the positioning frequency of the valve drive can be kept at a low level.

The continuous-action control can be used with the Fan Coil Controller for electromotive raise/lower valves or KNX valve drives.

Set temperature adjustment

Can set the temperature on the parameter setting page "Setpoints". Setting the actual output temperature can be calculated according to the following:

In comfort mode :

Heating : actual output = reference set temperature + temperature correction setting value.

Cooling : actual output = reference set temperature + temperature correction setting value + dead zone temperature + external temperature repair (In the case of a cooling, look at the "External temperature" in parameter page "Temperature setting" for instructions).

preparation mode :

Heating : actual output = reference set temperature - Decrement the standby mode + temperature correction setting value.

Cooling : actual output = reference set temperature + Incremental standby mode + temperature correction setting value.

Night mode :

Heating : actual output = reference set temperature + Decrement the night mode + temperature correction setting value.

Cooling : actual output = reference set temperature + Incremental night mode + temperature correction setting value.

Protected mode :

Heating : Actual output = overheat protection temperature.

Cooling : actual output = Frost protection temperature .

Note:

When you choose "Heating and cooling" in the "Controller mode in Heating/Cooling" of parameters page "General"

6. PARAMETERS AND COMMUNICATION OBJECTS (continued)

6.1 Project Design and Application (continued)

6.1.7 Type of control

Continuous control

Continuous control is based on the actual temperature and set the thermometer calculates a control value , and the valve opening degree of the continuous control, the temperature to achieve a comfortable condition. For example: the current control value is the maximum 50% of the control value , then the valve position will be under the control value to 50% open position ; If the control value output to the maximum control value , the valve will be fully open. Continuous control can be achieved "on" and "off" and "stop" three-step operation , the specific action as shown below:

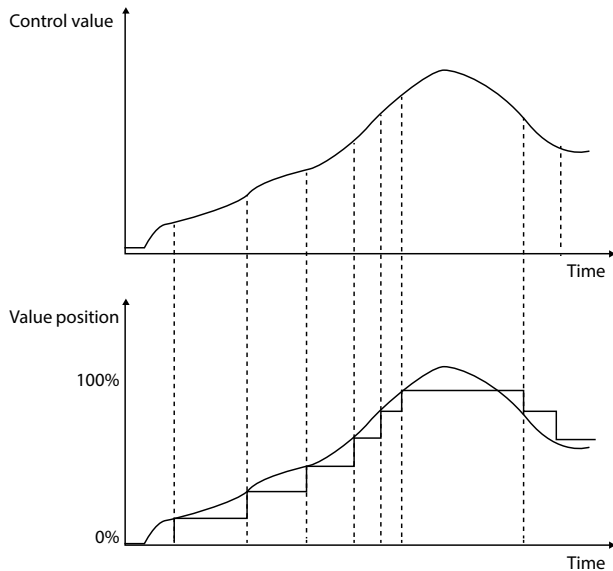

Continuous control , can achieve the most accurate temperature control , no considerable overshoot. Meanwhile, the positioning of the valve drive frequency can be maintained at a low level . Continuous control , be used to control the movements of the valve or fan coil controller KNX valve drives. PWM control PWM (pulse width modulation) control is based on the actual temperature and set the thermometer calculates a control value , and then calculates the valve opening and closing time of the switch valve is controlled to achieve a comfortable temperature state. On/off valve that only " full open" and " fully closed " two kinds of control operations. PWM control need to set a fixed cycle time period, For example, set the PWM period of 15 minutes , when the control value is the maximum 20% of the control value , the valve will open $15 * 20 \% = 3$ minutes ; Off $15 * 80 \% = 12$ minutes ; when the control value is the maximum control value of 50 % , the valve will open $15 * 50 \% = 7.5$ minutes ; off $15 * 50 \% = 7.5$ minutes . Diagram is as follows :

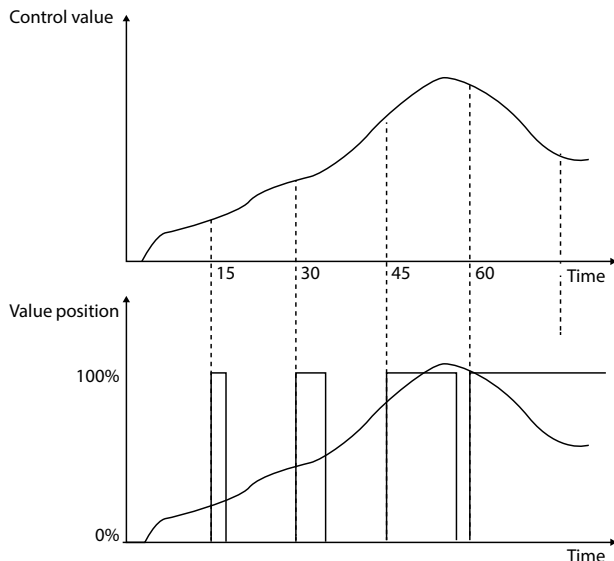

6. PARAMETERS AND COMMUNICATION OBJECTS (continued)

6.1 Project Design and Application (continued)

6.1.7 Type of control (continued)

PWM control is a relatively accurate adjustment , if you select the appropriate cycle , temperature overshoot will not be great , you can use a simple low cost general switching valve actuator . Fan Coil Controller can be used to control the common switching valve , electric valve or KNX valve drives.

6.2 Description of communication objects

Communication objects are devices on the bus to communicate with other media devices, That is only the communication objects can communicate on the bus. The following details description of the function of each communication object.

Note:

In the table below, attributes a column "C" represents the communication objects enable communication functions, "W" represents the value of the object through the communication bus rewritten, "R" represents the value of the object through the communication bus read, "T" stands for communication object has a transfer function, "U" represents the value of the communication objects can be updated.

No.	Function	Communication Object name	Data type	Flags
0	Actual temperature	Output, actual temperature Input, actual temperature	2 byte	C,R,T C,R,W,U
1	Actual temperature	Output, actual temperature error	1 bit	C,R,T
Objects 0: Interior actual temperature, can be read from the local PT100 sensors interface t, you can also get from the bus. Object 1: indoor temperature error flag, monitoring cycle by setting the indoor temperature to be monitored.If the actual temperature error occurs , then the object will be sent to the bus signal "1" to alarm.				
2	External temperature	Input, external temperature	2 byte	C,R,W,U
3	External temperature	Input, external temperature error	1 bit	C,R,T
Object 2: the outdoor temperature, the refrigeration case mainly for adjusting the set room temperature, i.e. when the external temperature is greater than the set point temperature value of "Minimum external temperature for correcting the set point", the outdoor temperature change of 3 degrees, the temperature setting value change of 1 degree. Object 3: outdoor temperature error flag, if the "Monitoring period for external temperature" parameter is received within a set time interval to the external temperature value is not updated, then the object is sent on the bus signal "1" to Alarm.				
4	Setpoint	Input, base setpoint	2 byte	C,R,W,U
5	Setpoint	Input, setpoint adjustment	2 byte	C,W,U
6	Setpoint	Output, instantaneous setpoint	2 byte	C,W,U
Object 4: The benchmark set temperature. As the setting value for the reference value of the actual output. The value of the existing heating but also cooling the case with dead zone temperature is used to determine the current status of the refrigeration or heating. Object 5: Basis set temperature correction. By writing to the object value, you can set the temperature to be modified. Object 6: the actual output set temperature value. The value is sent on the bus to the current set temperature.				
7	2-pipe operation	Output,heating Input,heating	1bit	C,R,T C,R,W,U
8	2-pipe operation	Output,cooling Input,cooling	1bit	C,R,T C,R,W,U
Object 7: heating enabled. Object 8: Refrigeration enabled. In this device as a master device, the two objects as two pipe fan coil open see, you can choose to receive or send parameters to enable the heating or cooling of the object. In a controlled device, the object 7 is also used to denote a separate heating or cooling, "0", indicates cooling, "1" indicates heating.				

6. COMMUNICATION OBJECTS (continued)

■ 6.2 Description of communication objects (continued)

No.	Function	Communication Object name	Data type	Flags
9	HVAC mode	Input, comfort mode	1bit/1 byte	C,W,U
10	HVAC mode	Input, night mode	1 bit	C,W,U
11	HVAC mode	Input,Frost/heat protection mode	1 bit	C,W,U
<p>Room Mode can be divided into three 1bit objects, (objects 9,10, 11) and one 1byte objects (object 9) to switch.</p> <p>1bit object: Object 9: Room Comfort mode. Object 10: Room night mode. Object 11: Room protected mode.</p> <p>Among them, the corresponding object to write "1" indicates that the corresponding room mode enabled; write "0" to cancel the corresponding room mode. Note: 3 1bit object has priority: protected mode (Frost / heat protection mode)> Comfort mode (Comfort mode)> Night mode (Night mode)> Ready Mode (Standby mode), when the object 9, the object 10 and object 11 received are zero, then the room is ready mode control mode.</p> <p>1byte: Enter the number and pattern relationship is as follows: Bit no: 0: Automatic 1: Comfort mode 2: Ready Mode 3: Room Mode 4: Protected Mode 5-255: Idle invalid</p>				
12	scene	Input, Scene number	1 byte	C,W,U
<p>The object is a scene number. There are six scenes, according to the number of different scenarios to different scenes.</p> <p>Through this communication object sends an 8bit command can be invoked or stored scenes. This communication object is enabled as long as the function is enabled for a scene. The following detailed description of the meaning of 8bit instruction.</p> <p>Let a 8bit instruction (binary coded): FXNNNNNN</p> <p>F: "0" Recalling a scene; "1" was stored scene; X: 0; NNNNNN: scene number (0 ... 63).</p> <p>Parameter setting options are 1 to 64, in fact, the corresponding object is 0 to 63. If the parameters are set in Scene 1, the communication object receives the scene should be 0.</p>				
13	Window contact	Input, window contact	1 bit	C,W,U
<p>This object is detected on the bus window switch. When the parameter Type of BU window contact options are "Normal" when the object is to write "1" indicates the windows shut, "0" indicates the windows open; option "Inverted", to the object write "0" indicates that windows are closed, "1" indicates the windows open. If it detects an open window on the bus, the controller will follow the parameters Window contact in the "Controller function for open window" to set the output control values.</p>				
14	Presence sensor	Input, presence detector	1 bit	C,W,U
<p>Presence detection, and presence sensor is connected. Object receives a "1" indicates that someone in the room; when receives "0" means no one in the room. When someone is detected, regardless of the current room modes and why modes are forced to switch back to the Comfort mode; when the person is not detected, the room mode switch back to the previous state of the room modes.</p>				
15	Fan	Input,manual operation of fan	1 byte	C,W,U
<p>Manually adjust the fan speed according to the parameters Fan set percentage of each file to adjust the fan speed. For example, when "Threshold value for switching on of fan speed 1" in the value of 10, the object 15 to be greater than 255 * 10% wind a trigger. Object 15 written value, the controller into manual operation mode.</p>				
16	Fan	Input,toggling to automatic mode	1 bit	C,W,U
<p>This object is used to switch the controller back to automatic control mode. If the current controller's control mode for testing or manual mode, the object through to write "1" to switch back to automatic control mode control mode.</p>				

6. COMMUNICATION OBJECTS (continued)

■ 6.2 Description of communication objects (continued)

No.	Function	Communication Object name	Data type	Flags
17	Fan	Output,fancoil automatic or not	1bit	C,R,T
<p>Fan control mode status, 1 for the automatic control mode, 0 to manual / test mode.</p>				
18	Fan	Output, speed 1/ fan speed status	1bit/1 byte	C,T
19	Fan	Output, speed 2/ speed:0-100% Input, automatic operation of fan	1 bit 1 byte	C,T C,W,U
20	Fan	Output, speed 3	1 bit	C,T
<p>For the controlled device: Automatic control object 19 is used to enter the fan control values. Object 18 and object 20 are not used.</p> <p>As the master device: When the parameter Fan in "Type of fan" of Local (max.3 speeds), with the object 18 (1byte) to represent the state of the local valve gear. 0 (0%) said that wind organs, 85 (33.3%) said that the first tranche, 170 (66.7%) said that the second tranche, 255 (100%) represents the third tranche.</p> <p>When the parameter Fan in "Type of fan" to KNX: 3 speeds, object 18, object 19, object 20 representing a wind speed, wind speed 2 speed 3. means open; "0" indicates Off.</p> <p>When the parameter Fan in "Type of fan" to KNX: 0 ... 100%, the object 9 when the wind a 33.3% output enable, 66.7%, wind 2 is enabled, 100% wind 3 enabled.</p> <p>When the parameter Fan in "Type of fan" of KNX on / off, the object 18 means that the switch fan. "1" means open; "0" indicates OFF.</p>				
21	Heating valve	Output, heating control value Input, heating control value	1 bit/1byte	C,T C,W,U
<p>When this device as the master device, the object represents the heating valve control output value, ie parameter Heating valve in the "Type of heating valve" for the "Bus valve, continuous" when the output is 1byte heating valve control value; "Bus valve, pulse width modulation"</p> <p>When the output is 1bit heating valve control values. When the device as a controlled device, the object as a heating valve control value input. Via an external controller for this device can be controlled heating valves, the control value, but also can be a 1bit 1byte.</p>				
22	Cooling valve	Output, cooling control value Input cooling control value	1 bit/1byte	C,T C,W,U
<p>When the device as a master device, the object represents the output cooling valve control value, ie parameter Cooling valve in the "Type of cooling valve" for the "Bus valve, continuous" when the output is 1byte refrigeration valve control value; "Bus valve, pulse width modulation", the output is 1bit cooling valve control values.</p> <p>When the device as a controlled device, the cooling valve control value object as input. Via an external controller can carry the equipment cooling valve control that value can be 1bit also be 1byte.</p>				
23	Controller	Output, PI control value	2 byte	C,R,T,U
<p>The output control value based on the set value and the actual temperature difference between the size of the pid control output values. Maximum output control value is 10000, the actual control value by the output control value accounted for the largest percentage of the ratio can draw fans and the state of the valve position</p>				
24	Dew point detector	Input, dew point alarm	1 bit	C,W,U
<p>This object is received for the refrigeration case dew point alarm signal. If the received value of "1", the object 23 outputs the control value is "0"; fans and the valve closed; receives the value "0", the cooling function is restored.</p>				
25	Temperature monitoring	Output, frost alarm	1 bit	C,R,T
<p>Frost alarm, when the temperature falls below the value of the setting parameter point of "Temperature limit value for frost alarm" in the "Temperature monitoring" value, the object 25 sends "1", otherwise "0".</p>				
26	Temperature monitoring	Output, temperature limit alarm	1 bit	C,R,T
<p>Temperature deviation detection, when the set temperature and the room temperature is greater than the difference between the parameter Temperature monitoring of the "Maximum value" the value, the object is sent to "1" or "0".</p>				
27	Error signal	Output, error information	1bit/1byte	C,R,T
<p>Error group reports can be divided into 1bit and 1byte report 1bit error when actual temperature, outdoor temperature error, frost alarms and temperature deviation alarm any one is wrong, it sends "1". 1byte error status report is as follows, Bit no: 0: Actual temperature error "0" is normal, "1" for the error 1: External temperature error "0" is normal, "1" for the error 2: Frost alarm "0" is normal, "1" for the error 3: Temperature monitoring "0" is normal, "1" for the error 4-7: Free (contains no information)</p>				

6. COMMUNICATION OBJECTS (continued)

6.2 Description of communication objects (continued)

No.	Function	Communication Object name	Data type	Flags
28	RHCC status	Output, RHCC status	2byte	C,R,T
RHCC Status Report Bit no: 0: fan coil error, "1" for the alarm, "0" is normal. 8: The heating or cooling, "0" cooling "1" heat 12: Dew point alarm, "1" for the alarm, "0" is normal. 13: frost alarm, "1" for the alarm, "0" is normal. 14: heat and cold alarm, "1" for alarm, "0" is normal.				
29	HVAC status	Output, HVAC status	1byte	C,R,T
HVAC Status Report Bit no: 0: Comfort: Comfort, "1" enabled, "0" means not enabled. 1: Standby: Standby mode, "1" enabled, "0" means not enabled. 2: Night: night mode, "1" enabled, "0" means not enabled. 3: Frost / Heat protection protected mode, "1" enabled, "0" means not enabled. 4: Dew Point dew point alarm, "1" indicates an error, "0" means no mistakes. 5: Heat / Cool heating or cooling, "1" heating, "0" indicates cooling. 6: Controller status controller state "1" indicates an error, "0" means no error. 7: Frost alarm frost alarm, "1" indicates an error, "0" means no mistakes.				
30	Window contact	Output, Window contact	1 bit	C,R,T,U
This object represents the local window contact switch or binary input status. Telegram value: "0": Contact open window open (input normal) "1": Contact close window close (input normal) "0": Contact closed window open (input inverted) "1": Contact open window close (input inverted) "Contact open window open" mean contact windows opencommunication ,object 30 then sends signal "0", when the contact is closed, the communication object sends signal "1"; "Contact closed window open" means that the contact is closed the windows, the communication object 30 sends the signal "0", then the contact opens, the communication object is sent then signal "1". "Input: normal" for the detected voltage input, communication objects 30 send signal "0"; no voltage input sends signal "1";				
31	Switch input	Input, Switch 1	1 bit	C,W,U
32	Switch input	Input, Switch 2	1 bit	C,W,U
33	Switch input	Input, Switch 3	1 bit	C,W,U
when local relays don't be used by the fan, these relays can be controlled through the following communication objects: Object 31: Fan's low position "LO" switch output. Object 32: Fan of the stall "Ml" switch output. Object 33: Fan's upscale place "HI" switch output. Among them, the "1" for the relay contacts are closed, and "0" for the relay contact opens				
34	Valve status	Output, heat valve status Input, heat valve switch 1	1bit/1byte 1bit	C,R,T C,W,U
1, as reported local heating valve switching state. The state of data type can be 1bit and 1byte: 1bit for the switching valve, only two states ON and OFF. "1" means open, "0" indicates Off. 1byte is for continuously adjustable valve which with the states of opening and closing and stop. 1byte used to indicate the size of the valve opening. 2, as the relay switch of the external input to control the heating valve "1". When the local access valve control valve relay is not available, this object can control the relay switch.				
35	Valve status	Input, heat valve switch 2	1 bit	C,W,U
As the relay switch of the external input to control the heating valve "2". When the local access valve control valve relay is not available ,when this object control relay switch				
36	Valve status	Output, cool valve status Input, cool valve switch 1	1bit/1byte 1bit	C,R,T C,W,U
1, as reported local heating valve switching state. The state of data type can be 1bit and 1byte: 1bit for the switching valve, only two states ON and OFF. "1" means open, "0" indicates Off. 1byte is for continuously adjustable valve which with the states of opening and closing and stop. 1byte used to indicate the size of the valve opening. 2, as the relay switch of the external input to control the heating valve "1". When the local access valve control valve relay is not available, this object can control the relay switch.				
37	Valve status	Input, cool valve switch 2	1 bit	C,W,U
As the switching relays of the external input control cooling valve "2". When the local access valve control valve relay is not available ,this object can be controlled by the relay switch.				

6. COMMUNICATION OBJECTS (continued)

6.3 Outline

Fan coil controller either as a master device can also be used as the controlled device .

Local(master device)

Local control fan coil controller acts as the master role , which according to the set temperature and the actual temperature difference between the change of the control value is calculated, to control the valve and the speed of the switch. In this mode , you can either select the local wind speed and valve control , or by bus to external wind speed fan coil and valve control.

Bus controlled device

As controlled by the external control fan coil controller role, and its temperature is not monitored and does not output the control value, but by an external controller (e.g., temperature and humidity sensors , temperature control panel, etc.) is sent to the control value for the output control . In this mode, the control value from external only can control the fan coil local control valve and speed controller.

6.4 General Parameter setting window "General"

General parameter setting interface shown in Figure 4.2 , this parameter setting interface is mainly set some basic parameters of fan coil controller. Intro of each parameter follows .

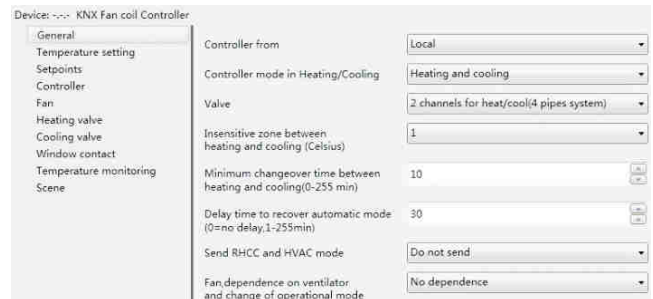

Fig. 6.4 "General"

Parameter: Controller from

- Options: Local
- Bus

This parameter sets the fan coil controller source. Wind speed and valve of fan coil controller can be locally controlled by an external controller can also be (such as temperature panel) control.

"Local" Expressed by the controller output control fan coil, as the master device; In this mode, you can either select the local wind speed and valve control; In this mode, you can either select the local wind speed and valve control, or by bus to external wind speed fan coil and valve control. "Bus" means fan coil controller input control by the external controller as the controlled device; in this mode, the external control values can only control fan coil controller's local and speed control valves . Since the control mode is not the same so the database parameter settings are not the same , we then introduce "Local" parameter settings , "Bus" in case of parameter settings to 4.11 do detail.

Parameter: Controller mode in Heating/Cooling

- Options: Heating
- Cooling
- Heating and cooling

This parameter sets the HVAC heating or cooling, select the "Heating" controller is in heating control state, then fan coil heating function only achieved heating; choose "Cooling" controller is in cooling mode, the cursor can only achieve cooling, if select "Heating and cooling" control both heating can also be implemented to achieve cooling, fan coil controller according to the set temperature and the actual temperature difference and the dead zone that automatic temperature heating or cooling. At this point the corresponding parameters will be open.

6. COMMUNICATION OBJECTS (continued)

■ 6.4 General Parameter setting window "General" (continued)

Parameter: Valve

- Options: 1 channel for heat/cool(2 pipes system)
- 2 channels for heat/cool(4 pipes system)

This parameter is set up out of the water pipe fan coil type, "1 channels for heat / cool (2 pipes system)" for the heating and cooling shared an inlet and outlet pipe, that is from hot and cold water pipes are out. At this point, you only need a valve to connect with fan coil heating valve controller output; "2 channels for heat / cool (4 pipes system)" for the heating and cooling, respectively, have their own access to water, requires two separate control valve to control out of hot and cold water.

Parameter: Choose heating or cooling by

- Options: Local
- Bus

This parameter is set for the two coil fan coil case is heating or cooling, because two cases can not know the current input is cold or hot water, they need via the communication object (object 7, objects 8) to control the feed cold water or hot water. "Local" means that the actual temperature and the set of local parameters to determine the output control of heating or cooling; "Bus" expressed by the external input control heating or cooling. This parameter is the "General" parameter entry "Valve" The available options are "1 channels for heat / cool (2 pipes system)" that it will be open.

Parameter: Insensitive zone between heating and cooling

- Options : C]0.5...6.0

This parameter is set automatically switches the dead zone heating and cooling temperatures. When the smaller the value of the dead zone heating and cooling the reaction according to the temperature, the faster switching, but the heating and cooling frequent exchange; larger values when the dead zone is not so frequent exchange heating and cooling, energy conservation, but switching heating and cooling of the reaction is slow. Dead zone temperature usage see 3.5 Introduction. The parameter in the parameter page "General" of the "Controller mode in Heating / Cooling" select "Heating and cooling" that it will be open.

Parameter: Minimum changeover time between heating and cooling

- Options : [min.] 0...255

This parameter is setting up the delay time when switching the heating and cooling. Mainly to prevent frequent switching heating and cooling, energy conservation.

Parameter: Delay time to recover automatic mode

- Options:[min.] 0...255

This parameter is setting up the delay time from the manual or test mode switch back to automatic mode. Option is "0", the controller does not automatically switch back to automatic mode until the user through the KNX communication objects or local button to switch back to automatic mode; for "1-255" when the manual mode or test mode will delay after the switch back to automatic mode.

Parameter: Send RHCC and HVAC status

- Options: Do not send
- Send on change
- Send cyclically

The parameter for the selection of fan coil controller sends status reports of HVAC and RHCC. "Do not send" is not send these two status reports; "Send on change" send report when the state values changed; "Send cyclically" state periodically sends , but also sent when changes, sent periodically after re-timing .

Parameter: Period of sending fan coil status

- Options: [min.] 1...255

This parameter is setting to send RHCC and HVAC state cycle time. This parameter is "Send cyclically" in the parameter "Send RHCC and HVAC status" option then it will be open.

6. COMMUNICATION OBJECTS (continued)

■ 6.4 General Parameter setting window "General" (continued)

Parameter: Fan, dependence on ventilator and mode change of operational mode

- Options: No dependence
- Switch fan to automatic on mode change
- Switch comfort mode on manual operate fan

This parameter is to set the fan and mode incidental. "No dependence" indicates no relationship between both of them; when "Switch fan to automatic on mode change" is selected and when the fan is in manual control, change modes via KNX room control packets, fan coil controller will automatically switch back to automatic control mode; when "Switch comfort mode on manual operate fan" is selected and the room of control mode is not comfortable , through the KNX packets to change speed, the fan coil controller will automatically switch back to the comfort mode.

■ 6.5 Parameter window: "Temperature setting"

"Temperature setting" parameter setting interface shown in Figure 4.3. The interface is primarily the basic parameters of the set temperature. "Actual temperature" and "External temperature" two parts, of which "External temperature" parameter to the "General" parameter page "Controller mode in Heating / Cooling" is selected for "Cooling" or "Heating and cooling" then it will be open, The following detailed description of each parameter settings.

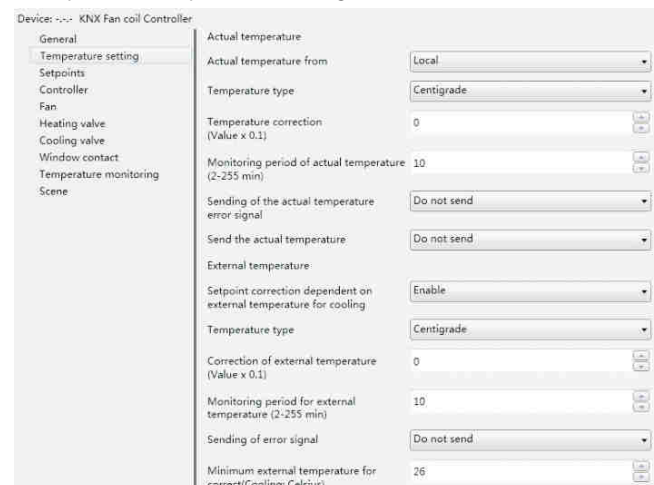

Fig. 6.5 "Temperature setting"

Actual temperature

Local actual temperature, the main way of collecting temperature setting can be carried out through the local pt100 temperature sensor reading, you can also get on the bus .

Parameter: Actual temperature from

- Options: Local
- Bus

This parameter is the source that required from the fan coil controller, "Local" means the local received the temperature from PT100 temperature sensor; "Bus" means to receive temperature from other devices via KNX BUS. Note: The fan coil controller needs to know the current heating or cooling output clearly to control to work properly, the heating or cooling can be the actual temperature and the set temperature compared to determine, in some cases need to clear through the communication objects, such as the two coils control systems and as a controlled device.

6. COMMUNICATION OBJECTS (continued)

■ 6.5 Parameter window: "Temperature setting" (continued)

Parameter: Temperature type

- Options: Centigrade
- Fahrenheit

This parameter is set to the bus output, or received from the bus type of the actual temperature. "Centigrade" indicates the actual temperature is expressed in degrees Celsius; "Fahrenheit" indicates the actual temperature is Fahrenheit. Wherein the relationship between Fahrenheit and Celsius are as follows: $F = 32 + ^\circ C \times 1.8$.

Parameter: Temperature correction

- Options : [val x 0.1°C] -50...50

This parameter is modified locally or from a temperature value deviation on the KNX bus. When the temperature sensor receives the temperature value and the actual value of the parameter deviation can be corrected. For example: no output before calibration temperature of 25 degrees, but the indoor temperature is 25.5 degrees, then the database where the calibration temperature must be set to 5 ($0.1 * 5$), and then re-download the database, it will have 25.5 degrees output temperature.

Parameter: Monitoring period of actual temperature

- Options: [min.] 2...255

The parameter to monitor the temperature cycle. When the temperature is up from the Bus, then within the set time did not update, then it is wrong temperature, the corresponding packet is sent "True"; when the temperature reading from the Local, at this set time has remained the same a temperature value, it is considered wrong temperature, the corresponding message will be sent "True". Error occurs when the control value output parameter page "Temperature monitoring" parameter "when actual temperature is absent or in event of frost" setting maximum control value (10,000) Percentage.

Parameter: Sending of error signal

- Options: Do not send
- Send on change
- Send cyclically

This parameter is setting to send the actual temperature of the wrong way. "Do not send" when an exception occurs for the actual temperature is not transmitted to the bus error status report; "Send on change" is the actual temperature of the abnormal state when there is a change on the transmission error status value, which is only made when actual temperature anomaly a "1" (True means 1), until the actual temperature returned to normal hair only a "0" (False means 0); "Send cyclically" send for the cycle, depending on the setting of the transmission time , time to send a message , but the actual temperature anomalies also sent packets, and sent at this time to re-cycle timing .

Parameter: Period of sending

- Options: [min.] 1...255

This parameter is setting when actual temperature occurs an exception, the controller sends the error status reporting time period to BUS. This parameter only "Sending of error signal" option to "Send cyclically" is visible.

Parameter: Send the actual temperature

- Options: Do not send
- Send on change
- Send cyclically

This parameter is setting to read from the local pt100 temperature sensor value and sent to the BUS. "Do not send" the local acquisition temperature does not occur on the bus made; "Send on change" for the local temperature changes when a certain value, the controller transport the temperature value on the bus; "Send cyclically" Send for the cycle, that is every once in a while to send a temperature value. This parameter is only "Actual temperature from" option for the "Local" visible.

6. COMMUNICATION OBJECTS (continued)

■ 6.5 Parameter window: "Temperature setting" (continued)

Parameter: Send temperature at variation of

- Options: 0.1...5

This parameter is to set the actual temperature variation. When the actual temperature changes every time the option value, the fan coil controller will be sent to the bus once the actual temperature. This parameter is only "Send the actual temperature" option to "Send on change" visible.

Parameter: Time lag of sending actual temperature

- Options: [min.] 1...255

This parameter is set to send the local actual temperature period time. This parameter is only "Send the actual temperature" option to "Send cyclically" visible.

External temperature

External temperature only in the case of a cooling occurs , the parameter item in the "General" parameter page "Controller mode in Heating / Cooling" is selected for "Cooling" or "Heating and cooling" is visible . Mainly used to adjust the room temperature setting , indoor outdoor temperature can not be too large. As below:

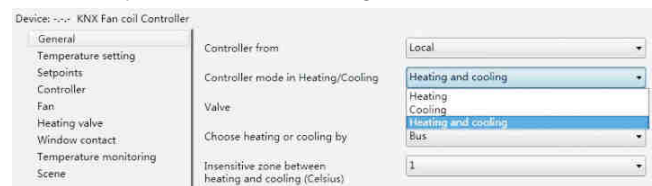

Fig. 6.5 "External temperature"

■ 6.6 Parameter window "Setpoints"

"Setpoints" parameter setting interface shown in Figure 4.4. It is for setting the basic setpoint temperature of heating or cooling. Divided into "Base setting", "Heating" and "Cooling" three parts, "Heating" and "Cooling" parameter can be seen when choosing the appropriate heating or cooling option in parameter "Controller mode in Heating / Cooling" in the "General" page, Following is detail description for each of the parameter settings.

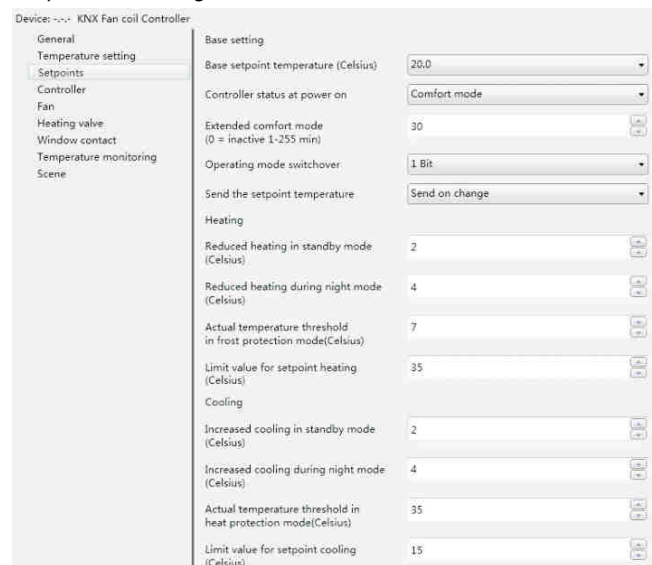

Fig. 6.6 Parameter window: "Setpoints"

6. COMMUNICATION OBJECTS (continued)

■ 6.6 Parameter window "Setpoints" (continued)

Base setting

Setting the basic setting for either heating or cooling

Parameter: Base setpoint temperature

Options: [° C] 15 ... 30

This parameter is a reference value to set the set temperature, the set temperature of room modes generated therefrom.

Parameter: Controller status at power on

Options: Standby mode
Comfort mode
Night setback
Frost protection

Setting of the operation mode when connecting the supply voltage, divided into preparation mode, comfort mode, night mode and frost protection mode.

Parameter: Extended comfort mode

Options: [min.] 0 ... 1-255

The comfort mode parameter is set delay time. When the setting is "0", it means do not use comfort mode delay function; when set value at 1-255, the room mode Night mode switch back from comfort mode, this function is enabled, comfort mode will be delayed user settings, when the delay time exceeds the set value, it will automatically switch to night mode. This mode is only for night mode and comfort mode switch.

Parameter: operating mode switchover

Options: 1bit
1byte

This parameter sets the operating room Switching mode.

Select 1bit, according to the writing of ON or Off, switch to a different mode. Switch to the attention of priority, if you want to enter the low level mode, you must first close the high level mode, otherwise unable to enter the low level mode. Mode priority is as follows: Mode of priority is as follows: protected mode (Frost / heat protection mode)> Comfort mode (comfort mode)> Night mode (night mode)> standby mode (standby mode).

When selected 1byte, 1 comfort mode, said standby mode 2, 3 for the night mode, 4 denotes a protected mode, different values are written into the mode is not the same.

Parameter: Send the setpoint temperature

Options: Send on change
Send cyclically

This parameter is set to send mode temperature setpoint. "Send on change" means that there is a change occurs when the set temperature set temperature, "Send cyclically" means that periodically sends the temperature setpoint.

Parameter: Period for cyclical sending

Options: [min.] 2 ... 255

This parameter is set to send the set temperature cycle time. In the parameter "Sending the setpoint temperature" Select "Send cyclically" is visible.

Heating / Cooling

The two parts under the "General" parameter page "Controller mode in Heating / Cooling" select the appropriate "Heating" or "Cooling" or "Heating and Cooling" see the different open. Mainly used to set the room temperature setting various modes.

Parameter: Reduced heating in standby mode

Parameter: Increased cooling in standby mode

Options: [° C] 0 ... 10

This parameter is set ready mode, the set temperature. When set to "Heating" mode, the standby mode is set as the reference value minus the temperature values of options; when set to "Cooling" Mode, the standby mode is set as a reference temperature value plus the value of the options available.

6. COMMUNICATION OBJECTS (continued)

■ 6.6 Parameter window "Setpoints" (continued)

Parameter: Reduced heating during night setback

Parameter: Increased cooling during night setback

Options: [° C] 0 ... 10

This parameter is set in night mode set temperature. When set to "Heating" mode, night mode setting temperature of the reference value minus the value of the options; when set to "Cooling" Mode, night mode setting temperature of the reference value plus the value of the options.

Parameter: Actual temperature threshold in frost protection mode

Options: [° C] 2 ... 10

Parameter: Actual temperature threshold in heat protection mode

Options: [° C] 5 ... 40

This parameter is set overheating or frost protection mode set temperature. When the indoor heating mode when the frost protection mode, when the room temperature falls to the options available for the set temperature value, the controller outputs a control not to fan coil temperature is below the set temperature value; cooling mode when the room is The overtemperature protection mode when the room temperature rises to a set temperature value of the option, the controller outputs a control not to fan coil temperature is higher than the set temperature value.

For example: When the room for the heating mode, this parameter is set at a temperature of 10 ° C, room temperature below 10 ° C, in order to play a protective role, the controller will output control ensure outdoor at 10 ° C or so.

When the room is cooling mode, the parameter setting temperature of 30 ° C, the outside temperature is higher than 30 C, is also meant to play a protective role, the system will output control ensures outdoor at 30 ° C or so.

Parameter: Limit value for setpoint heating

Options: [° C] 5 ... 40

Parameter: Limit value for setpoint cooling

Options: [° C] 5 ... 60

This parameter is set heating or cooling set temperature limits. When set to "Heating" mode, the set temperature is not higher than this value, if the output value is higher than the click; when set to "Cooling" Mode, the set temperature not lower than this value, if the output value is less than the click.

■ 6.7 Parameter setting interface "Controller"

"Controller" parameter setting interface shown in Figure 4.5. The interface s mainly set up in the case of heating or cooling the parameters of the PI controller. The following detailed description of each parameter settings.

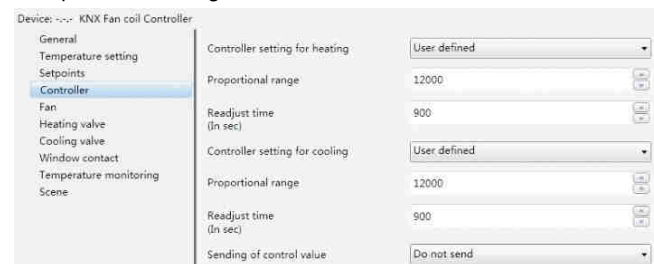

Fig. 6.7 "Controller" parameter setting interface

6. COMMUNICATION OBJECTS (continued)

6.7 Parameter setting interface "Controller" (continued)

Parameter: Controller setting for heating

Parameter: Controller setting for cooling

- Options: - Slow
- Normal
- Fast
- User defined

This parameter is set when setting the heating or cooling of PI corresponding Slow: the I-gain 1800 s
Normal: the I-gain 900 s
Fast: the I-gain 450 s

Parameter: Proportional range

- Options: 0 ... 65,535

Parameter: Readjust time

- Options: 0 ... 65,535 (900)

Setting parameters of the PI controller. In the parameter "Controller setting for heating" or "Controller setting for cooling" option is "User defined" visible.

Parameter: Sending of control value

- Options: - Do not send
- Send on change
- Send cyclically

The transmission control parameters by value. "Do not send" is not sent to the bus control value; "Send on change" for the control value is changed certain value, the controller was sent on to the bus control value; "Send cyclically" Send for the cycle, that every once in a while sends a control value.

Parameter: Period for cyclical sending of control value

- Options: [min.] 2 ... 255

The parameter values for the cycle time of transmission control. That is periodically sent once control values. Parameter "Send of control value" option to "Send cyclically" is visible.

Parameter: Differential value for sending the control value

- Options: [%] 1 ... 10

The parameter values for the control of the percentage change in the option, the fan coil controller sends a control value to the bus. In the parameter entry "Send of control value" option for the "Send on change" is visible.

6.8 Parameter setting interface Fan"

"Fan" parameter setting interface as shown in Figure 4.6.1. The interface is mainly to set the fan speed of some parameters. The following detailed description of each parameter settings.

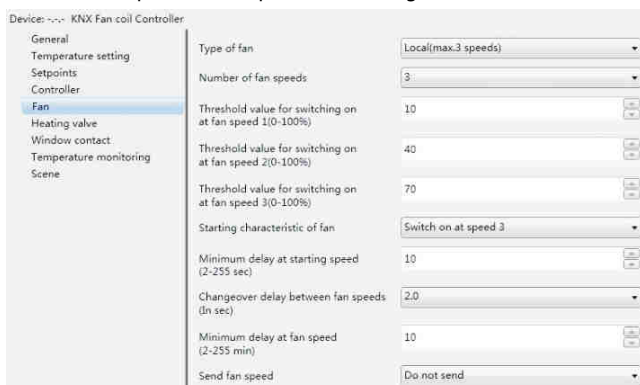

Fig. 6.8 "Fan" parameter setting interface

6. COMMUNICATION OBJECTS (continued)

6.8 Parameter setting interface Fan" (continued)

Parameter: Type of fan

- Options: - No fan
- Local (max. 3 speeds)
- KNX: on / off
- KNX: 3 speeds
- KNX: 0 ... 100%

This parameter sets the type of the fan.

"No fan" with no fan control, and no parameter is optional;

"Local (max. 3 speeds)" for the controller controls the local relay output to achieve control fan speed adjustment; Options "KNX: on / off", "KNX: 3 speeds", "KNX: 0 ... 100%" as the controller via KNX to control the packets on the bus other types of wind turbine output. When the option is "No fan", "KNX: on / off", "KNX: 3 speeds" and "KNX: 0 ... 100%", the controller of the fan three way switch through the object 31, the object 32 and the object 33 to control the output.

Parameter: Number of fan speeds

- Options: - 1
- 2
- 3

This parameter is the number of stalls set up wind speed. According to the actual needs of fan coil, the user can select the fan speed is divided into several files. This parameter is only in the parameter "Type of fan" option for the "Local (max.3speeds)", "KNX 3speeds" and "KNX 0 ... 100%" is visible.

Parameter: Threshold value for switching on at fan speed 1

Parameter: Threshold value for switching on at fan speed 2

Parameter: Threshold value for switching on at fan speed 3

- Options: [%] 0 ... 100

The parameter for the fan stall threshold setting. The output is the output gear of the actual control value representing the maximum control value (10000) to achieve a percentage. "Threshold value for switching on at fan speed 1" means that the output gear a threshold; "Threshold value for switching on at fan speed 2" means that the output gear 2 Threshold "Threshold value for switching on at fan speed 1" indicates file Bit 3 of the output threshold value. Threshold levels 1 <stall threshold value 2 <threshold value 3 stalls. This parameter is only in the parameter "Type of fan" option for the "Local (max.3speeds)", "KNX 3speeds" and "KNX 0 ... 100%" is visible.

Parameter: Starting characteristic of fan

- Options: - Switch on at speed 1
- Switch on at speed 2
- Switch on at speed 3

This parameter is set to start the fan speed, in order to stably start the fan motor, preferably starting from the high speed, so that a high torque can be obtained. When the start time has elapsed, the wind speed is controlled by the controller on the output value. Fans action following figure 4.6.2 below. This parameter is only in the parameter "Type of fan" option for the "Local (max.3speeds)", "KNX 3speeds" and "KNX 0 ... 100%" is visible.

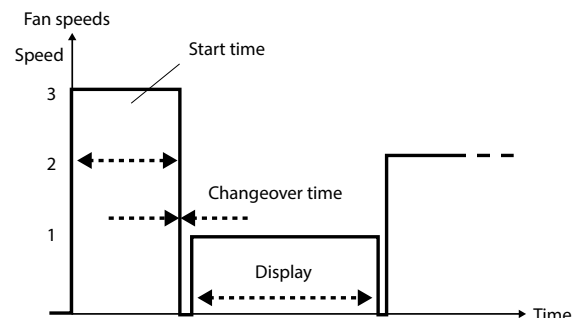

Fig. 6.8 Fan gear shifting mode

6. COMMUNICATION OBJECTS (continued)

6.8 Parameter setting interface Fan" (continued)

Parameter: Minimum delay at starting speed

Options: [sec.] 2 ... 255

This parameter is start the fan when the residence time of start-up files.

Parameter: Changeover delay between fan speeds

Options: [sec.] 0.5 ... 10

This parameter is switched when the wind speed stall, delay some time.

Parameter: Minimum delay at fan speed

Options: [min.] 2 ... 255

This parameter is to set the minimum dwell time wind. In order to prevent excessive speed gear shifting too dense, so enter each file will stay options in the time.

Parameter: Send fan speed status

- Options: -Do not send
- Send on change
- Send cyclically

The stall state parameter is a way to send the room. "Do not send" is not sent on to the bus speed of the status report; "Send on change" as the wind changes state reports status to the bus; "Send cyclically" is sent once every so often cycle speed state, when there is wind condition Change is also sent, this time sending time re-timing cycle. This parameter is only in the parameter "Type of fan" option for the "Local (max.3speeds)" is visible.

Parameter: Minimum delay at starting speed

Optional parameters: [sec.] 2...255

This parameter is start the fan when the residence time of start-up files.

Parameter: Changeover delay between fan speeds

Optional parameter: [sec.] 0.5...10

Parameter: Minimum delay at fan speed

This parameter is switched when the wind speed stall, delay some time

Optional parameter: [min.] 2...255

The parameters are to set the wind speed duration of stay. To prevent wind speed gear switch too quickly, each gear will stay a duration of time.

Parameter: Send fan speed status

- Optional parameter: Do not send
- Send on change
- Send cyclically

This parameter is a way to the room stall condition. "Do not send" is not sent on to the bus speed of the status report; "Send on change" as the wind changes state report status to the bus. Send cyclically" is sent once every so often cycle speed state, when the wind speed is also sent the status has changed, this time to re-cycle timing transmission time. This parameter is only in the parameter "Type of fan" option for the "Local (max. 3speeds) "is visible.

6.9 Parameter setting interface "heating valve" and "cooling valve"

Heating valve and cooling valve's parameter setting .As picture 4.7.1 and 4.7.2 shown, They are respectively used to set some parameters of the heating and refrigeration valves. The following detailed settings for each parameter.

6. COMMUNICATION OBJECTS (continued)

6.9 Parameter setting interface "heating valve" and "cooling valve" (continued)

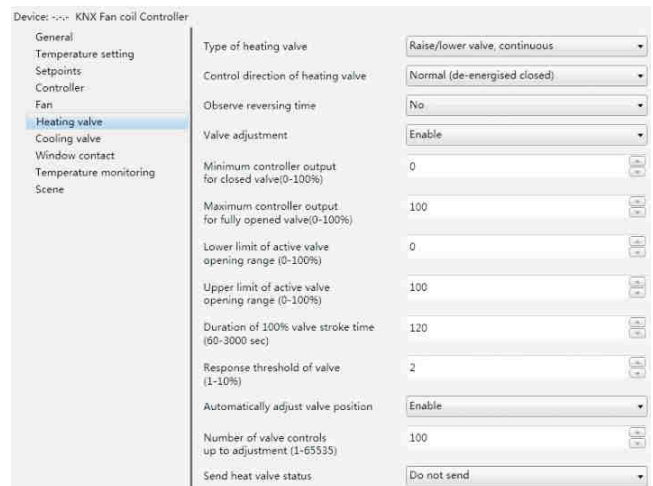

Fig. 6.9 "Heating valve" Parameter setting interface

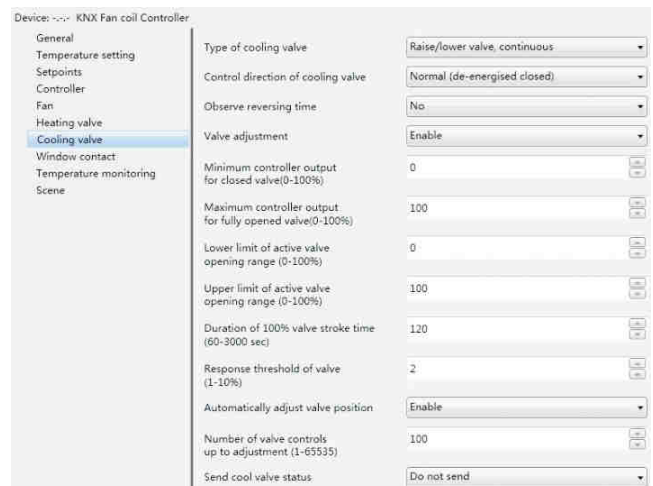

Fig. 6.9 "Cooling valve" Parameter setting interface

Parameter : Type of heating valve

Parameter: Type of cooling valve

- Option Parameter: -Raise/lower valve, continuous
- Raise/lower valve, pulse width modulation
- Thermal valve
- BUS valve, continuous
- BUS valve, pulse width modulation

This parameter is to set the controller controls the type of valve. It can control the local valve also can control valves on the KNX bus. Valve has two types, one for the switch type, and the other is a continuous type.

Raise/lower valve, continuous" Represents the local movements of ontinuous control valve;

"Raise/lower valve, pulse width modulation"represent the rise and fall of local PWM control valve.

BUS valve, continuous"represnet bus continuous valve;

BUS valve, pulse width modulation"express the switching valve on the bus.

Parameter: Control direction of heating valve

Parameter: Control direction of cooling valve

- Optional: -Normal (de-energised closed)
- Inverted (de-energised open)

6. COMMUNICATION OBJECTS (continued)

■ 6.9 Parameter setting interface "heating valve" and "cooling valve" (continued)

This parameter is to set the direction of the valve switch. Continuous valve "Normal (de-energised closed)" is positive; "Inverted (de-energised open)" to reverse. Switch valves "Normal (de-energised closed)" indicates a normally closed switch; "Inverted (de-energised open)" indicates normally open switch.

Parameter: Observe reversing time

Option: -No...500ms...1.5s

This parameter is set to toggle continuous valve switch delay time. When the valve type is continuously adjustable, in order to prevent frequent switching valve switch, opening or closing the valve needs to be suspended for some time. This parameter is only in the parameter entry "Type of heating valve" or "Type of cooling valve" select "Raise / lower valve, continuous" or "Raise / lower valve, pulse width modulation" is visible.

Parameter: Valve adjustment

Option: -Enable
-Disable

The parameter can be adjusted to make the characteristic curve of the valve

Parameter: Minimum controller output for closed valve

Parameter: Maximum controller output for fully opened valve

Parameter: Lower limit for active valve opening range

Parameter: Upper limit for active valve opening range

Option: [%] 0...100

This parameter is for setting the valve output characteristic curve "Minimum controller output for closed valve" show the scope of the control values of lower limit value "Maximum controller output for fully opened valve" show the the scope of the controlled variable upper limit; "Lower limit for active valve opening range" This value represents the lower limit value of the valve is limited;

"Upper limit for active valve opening range" This value represents the upper limit value of the valve is limited.

For different valves, the limited is different: "Raise/lower valve, continuous" travel time is limited; "Raise/lower valve, pulse width modulation", "Thermal valve" and "BUS valve, pulse width modulation" PWM cycle is limited; "BUS valve, continuous" Restricted is made out of a heating or cooling control values. This parameter is only in the parameter entry "Valve adjustment" select "Enable" is visible.

To Raise/lower valve, continuous valve as an example, the output value of the diagram.

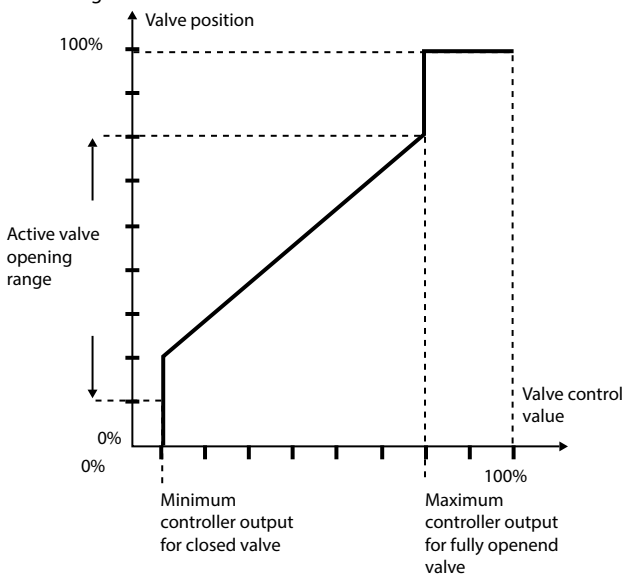

6. COMMUNICATION OBJECTS (continued)

■ 6.9 Parameter setting interface "heating valve" and "cooling valve" (continued)

Parameter: Duration of 100 % valve stroke time

Option: [sec.] 60...3,000

This parameter is set continuous valve travel time. Travel time refers to the valve from the closed to open to the maximum time value, this parameter only in the parameter entry "Type of heating valve" or "Type of cooling valve" select "Raise / lower valve, continuous" or "Raise / lower valve, pulse width modulation" when visible.

Parameter: Response threshold of valve

Options: [%] 1 ... 10

The parameter values for the setting controls the amount of change. When the control value percentage change of the parameter, the controller will output once the valve control. Therefore, the larger value of this parameter to adjust the switching frequency of the smaller value, on the contrary, the smaller the value, adjust the valve's switching frequency is greater. This parameter is only in the parameter entry "Type of heating valve" or "Type of cooling valve" select "Raise / lower valve, continuous" or "BUS valve, continuous" when visible

Parameter: Automatically adjust valve position

Option: -Enable
-Disable

The parameter settings are automatically corrected for the continuous valve opening. This parameter is only in the parameter entry "Type of heating valve" or "Type of cooling valve" select "Raise / lower valve, continuous" or "Raise / lower valve, pulse width modulation" when visible.

Parameter: Number of valve controls up to adjustment

Option: 1...65535

This parameter is set automatically correct valve opening count. In continuous valve opening and closing process, the valve stop time period of one frequency each, when the count equals the set count value, the valve will be fully closed, the valve closing time is: travel time 0.5 * (0.5 * journey time: maximum of 1min). This parameter is only in the parameter entry "Automatically adjust valve position" of the option to "Enable" when open see.

Parameter: Cyclic time for heating valve

Parameter: Cyclic time for cooling valve

Option: for heating valve [min.] 1...255

Option: for cooling valve [min.] 1...255

This parameter is the time period of the PWM control. The larger the value of this parameter, the valve switching frequency is smaller, on the contrary, the smaller the value, the more frequent valve switch. This parameter is only in the parameter entry "Type of heating valve" or "Type of cooling valve" select "Raise / lower valve, pulse width modulation", "Thermal valve" or "BUS valve, pulse width modulation" can be seen.

Parameter: Send heat valve status

Parameter: Send cool valve status

Options: -Do not send
-Send on change
-Send cyclically

This parameter is set to send the local way valve status report. "Do not send" on the bus to not to send local valve status report; "Send on change" as a local change in a certain amount of valve status report to the bus state; "Send cyclically" is sent once per cycle intervals local valve status. This parameter is only in the parameter entry "Type of heating valve" or "Type of cooling valve" select "Raise / lower valve, pulse width modulation", "Thermal valve" or "BUS valve, pulse width modulation" when visible.

6. COMMUNICATION OBJECTS (continued)

■ 6.9 Parameter setting interface "heating valve" and "cooling valve" (continued)

Parameter: Differential heat value for sending
 Parameter: Differential cool value for sending

Options: [%] - 1 ... 10

This parameter sets the local valve status change. When the valve is continuously changing the local value of the parameter, the controller sends a valve to the bus state values. This parameter is only in the parameter entry "Send heat valve status" or "Send cool valve status" select "Send on change" when open see.

Parameter: Send heat valve status period
 Parameter : Send cool valve status period

Options: [min.] - 2 ... 255

This parameter is set to send the local valve state the time period . This parameter is only in the parameter entry "Send heat valve status" or "Send cool valve status" select "Send cyclically" when open see .

Parameter : Send of 1 byte control value

Options: -Send on change
 -Send cyclically

This parameter is set to control external continuous valve control value is sent. This parameter is only in the parameter entry "Type of heating valve" or "Type of cooling valve" select "Raise / lower valve, continuous", "Raise / lower valve, pulse width modulation" or "Raise / lower valve, pulse width modulation" when open see.

Parameter : Differential value for sending the control value

Options: [%] - 1 ... 10

This parameter is set when the external continuous valve control options in the percentage change in value is sent when a valve control values. This parameter is only in the parameter entry "Send of 1 byte control value", select "Send on change" when open see .

Parameter : Period for cyclical sending of control value

Options : [min.] - 2 ... 255

This parameter is set to send out an external continuous controller valve control value cycle. This parameter is only in the parameter entry "Send of 1 byte control value", select "Send cyclically" when open see.

■ 6.10 Parameter settings interface "Window contact"

"Window contact" parameter setting interface shown in Figure 4.8 , the page is mainly used to set the window switch status parameters. The following detailed description of each parameter settings.



Fig.6.10 "Window contact"

Parameter: Type of BUS window contact

Options: -No BUS sensor
 -Normal
 -Inverted

The parameter settings from the windows on the bus type of contact "No Bus sensor" means that no bus window sensor; "Normal" indicates the input mode to forward the bus window, the object 13 receives the bus up the "0" is that the windows are opened, "1" is turned off; "Inverted" indicates that the bus windows input mode is reverse, ie up to the bus object 13 receives "1" is that the windows are open, "0" is off. When the controller detects the windows open, the controller will output parameter entry "Controller function for open window" in the parameters set.

6. COMMUNICATION OBJECTS (continued)

■ 6.10 Parameter settings interface "Window contact" (continued)

Parameter: Type of local window contact

Options: -No local sensor
 -Contact open window open
 -Contact closed window open
 -Input normal
 -Input inverted

This parameter is set up a local window switch contacts or binary input. "No local sensor" means no window switch contact sensor(Binary input is invalid); "Contact open window open" means that the windows contacts open , the communication object 30 sends "0", the contacts close a communication object sends "1"; "Contact closed window open" means that the windows closed contacts , the communication object 30 sends "0", the contacts open communication object sends "1". "Contact open window open" and "Contact closed window open" In both cases, the controller detects the windows open , the controller will output parameter entry "Controller function for open window" in the set parameters; while "Input: normal" input voltage is detected , the communication object 30 sends "1", send "0"; "Input: inverted" voltage input is detected , the communication object 30 sends "0"; opposite to send "1"; "Input: normal" and "Input: inverted" detects only the binary input status does not affect the fan coil controller's normal output.

Parameter : Delay for window contact

Options: [s] 0 ... 255

This parameter is the window detection delay time. When the window is opened temporarily, not always open, can use this parameter to distinguish the time, that is, when the window opening time value set in the parameter within the window that has not been opened, if the time exceeds the setting value, then that window has been opened .

Parameter : Controller function for open window

Options: -Normal (active)
 -Control value = 0 (all off)
 -Control value unchanged

The parameter setting window is opened for the operation of the controller. "Normal" fan coil controller output at normal control value , "Control value = 0 (all off)" fan coil controller output control value is 0 , then the fan coil valves and wind are closed. "Control value unchanged" for the fan coil controller maintains a constant output current value .

■ 6.11 Parameter settings interface "Temperature monitoring"

"Temperature monitoring" parameter setting interface shown in Figure 4.9, the page is primarily used to set the temperature alarm condition parameters. The following detailed description of each parameter settings.

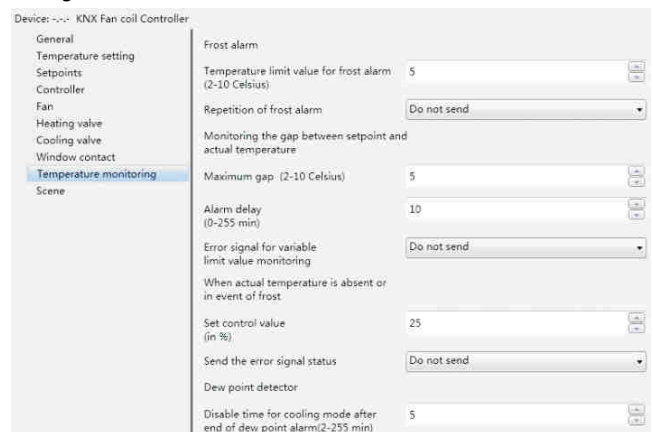

Fig.6.11 Parameter setting window of "Temperature monitoring"

6. COMMUNICATION OBJECTS (continued)

■ 6.11 Parameter settings interface “Temperature monitoring”(continued)

Frost alarm

Parameter: Temperature limit value for frost alarm

Options: [°C] 2...10

Setting the temperature of frost alarm. When the room temperature is lower than this setting one, the controller will send the signal of frost alarm to the bus.

Parameter: Repetition of frost alarm

Options: -Do not send
-Send on change
-Send cyclically

Setting the mode of sending out the frost alarm. “Do not send” means don’t send the frost alarm to the bus; “Send on change” means sending the signal to the bus when the frost alarm is changed; “Send cyclically” means sending the signal periodically, and also the time when the frost alarm is changed, after that, the cycle time is recounted.

Parameter: Period of cyclical sending of frost alarm

Options: [min.] 2...255

Setting the cycle of sending the signal of frost alarm. This parameter is available only when you select “Send cyclically” in parameter “Repetition of frost alarm”.

Parameter: Maximum gap

Options [C] 2...10

Setting the alarm value between actual temperature and setting temperature. When the gap between the actual temperature and setting temperature is larger than the setting value, controller will send signal of alarm to the bus.

Parameter: Alarm delay

Options: [min.] 0...255

Setting the delay time of sending out the gap alarm. When the gap between actual temperature and setting temperature is larger than the setting parameter “Maximum gap”, the controller will not send the alarm to the bus immediately, instead it will detect if the gap keeps larger than the value during the delay time, if yes, the controller will send the alarm to the bus after the delay time, if not, it won’t send the alarm.

Parameter: Error signal for variable limit value monitoring

Options: -Do not send
-Send on change
-Send cyclically

Setting the mode of sending out the gap alarm. When the gap between actual temperature and setting temperature is larger than the setting value, set the mode of sending out the gap alarm. “Do not send” means don’t send the alarm to the bus; “Send on change” means sending the signal to the bus when the alarm is changed; “Send cyclically” means sending the signal periodically, and also the time when the alarm is changed, after that, the cycle time is recounted.

Parameter: Period of sending error signal

Options: [min.] – 1...255

Setting the cycle of sending the signal of gap alarm. This parameter is available only when you select “Send cyclically” in parameter “Error signal for variable limit value monitoring”.

when actual temperature is absent or in event of frost

Parameter: Set control value

Options: [%] – 0...100

Setting the output value of the controller when the setting temperature is error. When the actual temperature is absent or in event of frost, controller will send out the value according to the percentage of the setting parameter.

6. COMMUNICATION OBJECTS (continued)

■ 6.11 Parameter settings interface “Temperature monitoring”(continued)

Parameter: Send the error signal status

Options: -Do not send
-Send on change
-Send cyclically

Setting the mode of sending out the error sets. Error sets including: indoor temperature alarm, outdoor temperature alarm, frost alarm, gap alarm, dew point alarm, KNX window opened alarm, and local window opened alarm. You could send by 1 bit or 1 byte. “Do not send” means don’t send the error sets to the bus; “Send on change” means sending the signal to the bus when the error sets are changed; “Send cyclically” means sending the signal periodically, and also the time when the error sets are changed, after that, the cycle time is recounted.

Parameter: Period of sending error information

Options: [min.] 1...255

Setting the cycle of sending the signal of error sets. This parameter is available only when you select “Send cyclically” in parameter “Send the error signal status”.

Parameter: Group Errors report type

Options: -1 Bit
-1Byte

Setting the type of sending out the error sets. “1 Bit” means when whatever one alarm of the error sets is happened, controller will send the signal of alarm in 1 bit. “1 Byte” means each alarm of the error sets, each number represents:

- Bit no: 0: indoor temperature alarm
- 1: outdoor temperature alarm
- 2: frost alarm
- 3: gap alarm
- 4: dew point alarm
- 5: KNX window opened alarm
- 6: local window opened alarm
- 7: reserve

This parameter is available only when you select “Send on change” or “Send cyclically” in parameter “Send the error signal status”.

Dew point detector

Parameter: Disable time for cooling mode after end of dew point alarm

Options: [min.] – 1...255

Setting the disable time for cooling mode after end of dew point alarm. When fan coil controller receives dew point alarm from bus, it will shut down the valve and fan, and recover when the alarm is clear and the disable time is over.

■ 6.12 Parameter setting window “Scene”

Fig. 4.10 is the parameter setting window of “Scene”. It is used to set the scene parameter, such as the mode of room, heating or cooling, wind speed, etc. When you use scene, the controller will default it is manual control mode. Hereunder is the detail of each parameter.

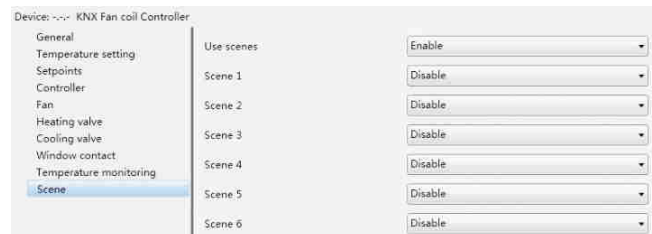

Fig. 6.12 Parameter setting window “Scene”

6. COMMUNICATION OBJECTS (continued)

■ **6.12 Parameter setting window "Scene" (continued)**

Parameter: Use scenes

- Options: -Enable
- Disable

Setting the scene. There are 6 scenes can be choosed.

Parameter: Scene 1-6

- Options: -Enable
- Disable

There are 6 scenes can be choosed, but each time, you can select only 1 scene.

Parameter: Scene number

- Options: 1...64

Setting the scene numbers.

Parameter: Mode

- Options: -Standby mode
- Comfort mode
- Night setback
- Frost protection

Parameter: Fan

- Options: -No change
- High
- Medium
- Low
- Off

Setting the wind speed of each scene. "No change" means keep the same speed. "High", "Medium", "Low" means the different wind speed. "Off" means to shut down the fan.

Parameter: Heating or Cooling

- Options: -No change
- Auto
- Heating
- Cooling

This parameter is to set the controller for heating or cooling. "No change" means that at the current value of the output of heating or cooling; "Auto" means that the heating or cooling by the controller; "Heating" means to set the controller for the heating mode; "Cooling" means to set the controller for the cooling mode. This parameter is only can be seen when be selected with the "Heating and cooling" in the "Controller mode in Heating / Cooling" function.

■ **6.13 External control parameter setting interface**

External control parameter setting interface is mainly used to set the external controller to the local control valve and fan parameters representing the device into the controlled mode. The following detailed description in this case the description of the parameter settings for each page.

External Control "General" parameter setting interface as shown in Figure 4.11.1, following detailed description of each of the parameter settings.

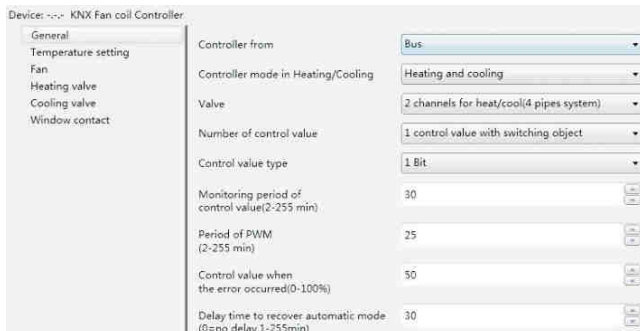

Fig. 6.13 External Control "General" parameter setting interface

6. COMMUNICATION OBJECTS (continued)

■ **6.13 External control parameter setting interface (continued)**

Parameter: Controller from

- Options: -Local
- Bus

This parameter is to set the fan coil controller, "Local" means that the controller output from the fan coil control, "Bus" indicates fan coil by an external controller input control, mainly through communication objects of the fan and valve control.

Parameter: Controller mode in Heating / Cooling

- Options: -Heating
- Cooling
- Heating and cooling

This parameter is the setting mode of the controller, can be individually heating or cooling, heating and cooling can also exist. Fan coil controller automatically according to the actual temperature output corresponding control values.

Parameter: Valves

- Options: -1 channels for heat / cool (2 pipes system)
- 2 Channels for heat / cool (4 pipes system)

This parameter is set up out of the water pipe fan coil type, "1 channels for heat / cool (2 pipes system)" for the heating and cooling shared an inlet and outlet pipe, the hot and cold water are in and out from the pipes. It only need a valve connected with output of the fan coil heating valve controller; "2 channels for heat / cool (4 pipes system)" for the heating and cooling, respectively, have their own access to water, you need two separate control valves hot and cold water in and out.

Parameter: Number of control value

- Options: -1 control value with switching object
- 2 Control values

This parameter is to set the external input control valve communication object number in the "Parameter: Controller mode in Heating / Cooling" Select "Heating and cooling" when the open see. "1 control value with switching object" indicates that only a communication object on the heating valve and cooling valve control (object 21), switching of heating and cooling through a communication object (object 7) to achieve; "2 control values" means a two communication objects to separately control the heating valve and cooling valves.

Parameter: Control value type

- Options: -1 Bit
- 1 Byte

The parameter values for the selected data type of external control. "1Bit" represents an external input control value is 1bit; "1Byte" represents an external input control value id 1 Byte. Local heating and cooling valve switch based on this control value for output control.

Parameter: Monitoring period of control value

- Options: [min.] 2 ... 255

The parameter values for the monitoring of external control time period, if the control value has not been updated, and the time have over. This option is longer than the time set, but longer than the time set this option, it is considered an external controller error, the controller based on the output of user-set parameters.

Parameter: Period of PWM

- Options: [min.] 2 ... 255

This parameter is the external controller error of the PWM cycle. When the control value of the external controller is "1Bit" and the control value error is detected, the controller output will follow the PWM cycle. This parameter is only can be seen when in the parameter "Control value type" when select "1 Bit" value.

6. COMMUNICATION OBJECTS (continued)**■ 6.13 External control parameter setting interface (continued)****Parameter: Control value when the error occurred**

Options: 0 ... 100%

This parameter is when setting the external controller error of control value output percentage. External controller error, if the parameter entry "Control value type" option to "1 Bit", then the PWM output heating or cooling of the time as a parameter entry "Period of PWM" multiplied by the time set in this parameter entry percentage; if the parameter entry "Control value type" option to "1 Byte", then the continuous control of the percentage of the value set by the user output.

Parameter: Delay time to recover automatic mode

Options: [min.] 0 ... 255

This parameter is set to switch back from other modes automatic mode delay time. Option is "0", the controller does not automatically switch back to automatic mode until the user through the KNX communication objects or local button to switch back to automatic mode; for "1-255" when the manual mode or test mode will delay after the switch back to automatic mode.

Fan, Heating valve, Cooling valve and Window contact can refer to the case when the control is internal.