

CONTENTS	Page
1. Use	1
2. Technical features	1
3. Dimensions	2
4. Connection	2
5. Operation	2
6. Standards and approvals	2
7. Maintenance	2
8. Communication Objects	3
8.1 Parameters	4
8.1.1 Functions, Objects	4
8.1.2 General	5
8.1.3 Scenes	5
8.1.4 Channels A-H	6

1. USE

The KNX dimming controller Cat. No. 0 026 63 can be used to control 8 different DALI outputs (channels), each of which can be connected to a group of 8 DALI (Digital Addressable Lighting Interface) ballasts maximum.

The DALI protocol allows not only to switch and dim the lighting but also to receive status, failure and error information from the ballasts.

Through its application program the main possible functions are:

- Switching, dimming and sending of a dimming value
- Selection between Normal, 1 level time and 2 level time switch mode
- Configuration of Switching ON/OFF, 0-100% and 100%-0% dimming time
- Configuration of a minimum/maximum dimming level
- Configuration of the same settings for all the channels or different settings per each channel
- Configuration of the Switching ON value, the possibility to switch through a dimming value and to switch changing the dimming value
- Configuration of the behaviour after main voltage failure/recovery and KNX BUS voltage failure/recovery
- 8-bit scenario configuration per each channel with the possibility to assign a channel to up to 16 scenarios
- Configuration of the switching/dimming/lamp failure and DALI status feedback

This controller has an internal 230 VAC power supply. In the event of failure of the KNX BUS, the loads can be managed manually via pushbuttons integrated on the front of the product.

2. TECHNICAL FEATURES

2.1 Climatic characteristics

- Resistance to climate change: EN 50090-2-2
- Ambient operating temperature: -5 to +45°C
- Storage temperature: -25 to +70°C
- Relative humidity (non-condensing): 5 to 93%

2.2 Electrical characteristics

- Supply voltage: 230 V~
- KNX BUS power supply: 29 V=
- Maximum power consumption: 6 W
- Current consumption on the KNX BUS: 11 mA

2.3 Mechanical characteristics

- Protection class (in accordance with standard EN 60529): IP 20

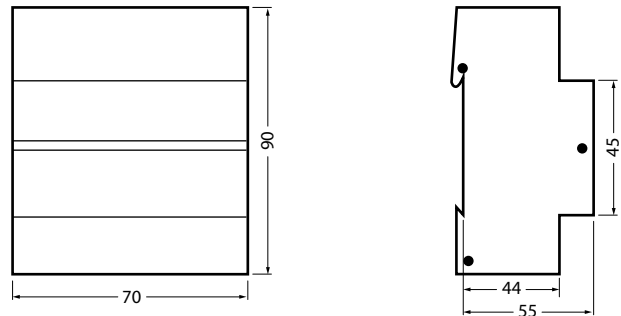

3. DIMENSIONS

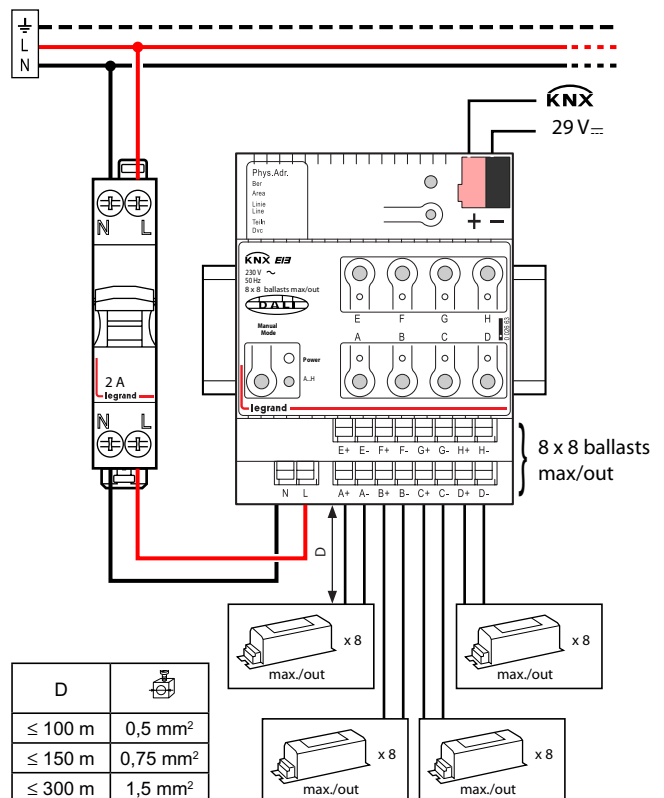

4. CONNECTION



4. CONNECTION (CONTINUED)

	4 x (Ø 0,6 <math>< 8\text{ mm}</math> <math>< \text{Ø } 0,8</math>)
	DALI $\leq 1,5\text{ mm}^2$

5. OPERATION

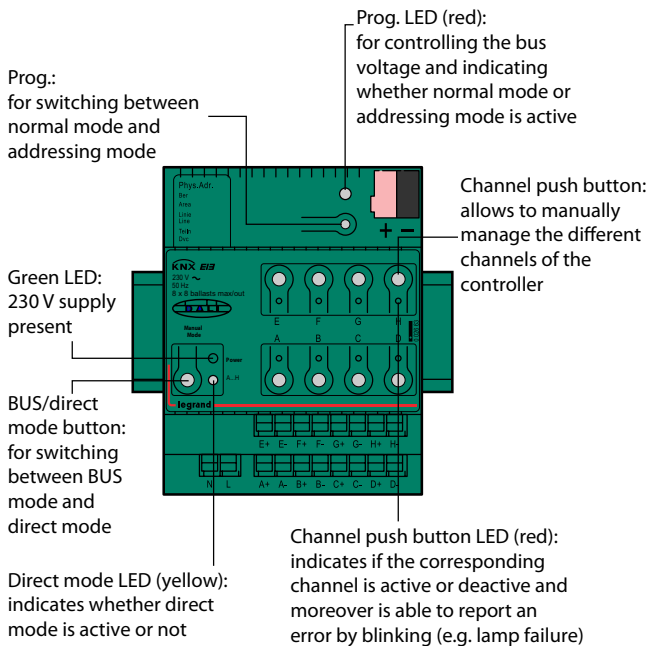

Application program

- The following functions and objects can be configured per each channel:
- Normal/Night mode operation, 1 or 2 timed dimming levels mode (per instance, to control colorimetric lighting)
 - Switching, dimming, dimming value send
 - End of time delay alarm before switching off the lights
 - Switching status, dimming value status, lamp failure feedback
 - DALI status feedback (failure of a lamp, short-circuit, failure of power supply)
 - Identical configuration of all 8 channels or individual configuration per each channel
 - 8-bit scene control with up to 16 configurable scenes per channel
 - Behaviour on BUS or mains voltage failure and recovery

Dimming times and limits, switching behaviour at the time of dimming, and dimming values can be defined.

5. OPERATION (CONTINUED)

BUS mode/direct mode

The built-in power supply in the 0 026 63 allows the actuator and lamps connected to its channels to operate even if it has not yet been commissioned with the ETS software or if communication with the KNX BUS has been interrupted. A pushbutton located at the bottom left of its front face is available for this purpose.

This button is used to activate direct mode and select a group of 4 channels:

- When the button is pressed for the first time:

the direct mode LED remains permanently ON to show that direct mode is active. Channels A to D can then be directly controlled.

- If the direct mode button is pressed for a second time:

the direct mode LED flashes to show that direct mode has been activated. Channels E to H can then be directly controlled.

- If the direct mode button is pressed for the third time:

the direct mode LED shows that direct mode goes out and the actuator reverts to BUS mode.

- In direct mode, a channel can be controlled using the corresponding push button on the front of the actuator: a short push on the upper button turns ON the load, a long push dims it up. Conversely, a short push on the lower button turns off the load whereas a long push dims it down.

The status of channels A-D, activation or deactivation and flashing in the event of an error is shown by the corresponding channel push button LED integrated in the lower push buttons whereas the status of channels E-H is shown by the corresponding channel push button LED integrated in the upper push buttons.

A parameter can be used to define whether direct mode has to be permanently or temporarily activated.

By default, direct mode operation lasts for 15 minutes.

Each time the push button is pressed in direct mode, the direct mode run timer is reset to the defined period. Once the operating time expires without the push button having been pressed again, direct mode ends automatically and BUS mode is reactivated (provided that communication is possible via the KNX BUS).

- In BUS mode, pressing the channel push button on the front of the actuator to activate or deactivate a channel has no effect.

When direct mode has been activated, any switching, retrieved value or scene command is stored temporarily and automatically executed once the device reverts to BUS mode.

6. STANDARDS AND APPROVALS

Electrical safety

- Degree of pollution (in accordance with standard IEC 60664-1): 2
- Protection type (in accordance with standard EN 60529): IP 20
- Overvoltage class (in accordance with standard IEC 60664-1): III
- BUS: safety extra low voltage (SELV) 24 VDC
- Conforming to standards: EN 50090-2-2 and EN 60669-2-1
- EMC requirements: conforming to standard EN 50090-2-2

Marking

- KNX, EIB CE

Note: All technical information is available at



www.legrandoc.com

7. MAINTENANCE

Clean the surface with a cloth.

Do not use acetone, tar-removing cleaning agents or trichloroethylene.

Caution: Always test before using other special cleaning products.

8. COMMUNICATION OBJECTS

The following view of the may dynamically vary depending on the selected parameters on page "Functions, Objects".

no.	Object name	Function	Type
01.D1.001	25 A8 DALI Switch/dim actuator	980801	5/WG1 525-1EB01
0	Status direct mode	On / Off	1 Bit
1	8-bit scene	recall / program	1 Byte
2	Night mode, Channel A	On / Off	1 Bit
3	Switching, Channel A	On / Off	1 Bit
4	Dimming, Channel A	Brighter / Darker	4 Bit
5	Dimming value, Channel A	8-bit Value	1 Byte
6	Status switching, Channel A	On / Off	1 Bit
7	Status dimming value, Channel A	8-bit Value	1 Byte
8	Status lamp failure, Channel A	1=Fault, 0=ok	1 Bit
9	Status DALI, Channel A	Status	1 Byte

Obj	Object name	Function	Type	Flags
0	Status direct mode	On / Off	1 Bit	CRT
<p>It is reported via this object whether the actuator has been switched from bus mode to direct mode via the "Direct mode" button on the front of the device (Direct mode = ON) or has been switched from direct mode back to bus mode (Direct mode = OFF). When direct mode is switched on (the relevant yellow LED on the front of the actuator lights up or flashes), the direct switching and dimming of the actuator channels via the corresponding channel push buttons on the front of the actuator is enabled. The actuator does not carry out any switching, dimming or scene commands which are received via the KNX BUS but saves them as the desired setpoint state. After switching back to BUS mode (the yellow LED on the front of the actuator for displaying direct mode is switched off), the actuator compares the actual states of the channels with the stored setpoint states and automatically corrects any deviations.</p>				
1	8-bit scene	recall / program	1 Byte	CW
<p>The 8-bit scene with the number x is recalled (i.e. retrieved) or programmed (i.e. saved) via this object. Bits 0...5 contain the number x of the scene. If bit 7 = log. 1, the scene is programmed. If bit 7 = log. 0, it is recalled. Bit 6 has no meaning in this case and must be set to log. 0.</p>				
2	Night mode, Channel A	On / Off	1 Bit	CW
<p>The operating mode "Night mode" can be activated or deactivated for channel A via the KNX BUS with this object. The object can be sent e.g. by a push button, a time switch or a building automation system. If a logic 1 is received, the channel switches to night mode. In the operating mode "Night mode", the channel can no longer be switched ON permanently and may only be switched on for a limited time period (e.g. for 30 minutes to provide lighting for cleaning purposes). If the parameter "Warning before switching OFF" (see "General" parameter page) is set to "Yes", once the set operating time has elapsed, the dimming value of the channel is first set to 50% of the previous value for safety reasons and then fully dimmed down within approx. 30 s and then the channel is switched OFF. The end of the operating time can thus be detected and the lighting can be switched ON e.g. for a further 30 minutes by pressing again the light switch. If the object "Night mode" is not used for the channel, this channel can be switched ON permanently.</p>				

Obj	Object name	Function	Type	Flags			
3	Switching, Channel A	On / Off	1 Bit	CW			
<p>The telegrams for switching the ECGs connected to channel A ON or OFF are received via this object.</p>							
4	Dimming, Channel A	Brighter / Darker	4 Bit	CW			
<p>The dimming telegrams for channel A are received via this object.</p>							
5	Dimming value, Channel A	8-bit Value	1 Byte	CW			
<p>A dimming value for channel A is received via this object.</p>							
6	Status switching, Channel A	On / Off	1 Bit	CRT			
<p>Depending on the selected parameter setting, the current switching state of channel A can be queried via this object and also automatically sent if required when there is a change in the status.</p>							
7	Status dimming value, Channel A	8-bit Value	1 Byte	CRT			
<p>Depending on the selected parameter setting, the current dimming status (dimming value) of channel A can be queried via this object and also automatically sent if there is a change in the status. With the help of the parameter "Blocking time after change of state of dimming value", the sending of dimming value status telegrams can be restricted.</p>							
8	Status lamp failure, Channel A	1 = failure, 0 = OK	1 Bit	CRT			
<p>Depending on the selected parameter setting, a lamp failure on channel A can be queried via this object and also automatically sent if required.</p>							
9	Status DALI, Channel A	Status	1 Byte	CRT			
<p>Depending on the selected parameter setting, the status of the DALI bus of channel A can be queried via this object and also automatically sent if required. The following bit assignment is used to report the BUS status:</p>							
7	6	5	4	3	2	1	Bit 0
					DALI comm. failure	DALI short circuit	Lamp failure
<p>If bit 0 is set, a lamp failure at this channel is reported. If bit 1 is set, a short circuit of the DALI output is reported. If bit 2 is set, none of the DALI devices that are connected to the channel are responding (the DALI bus cable is then either interrupted or the power supply has failed for all the DALI ECGs of this group i.e. there is no AC 230 V present at the ECGs).</p>							

The explanations above apply to the communication objects from 10 to 65 of channels B to H.

8. COMMUNICATION OBJECTS (CONTINUED)

8.1 Parameters

8.1.1 Functions, Objects

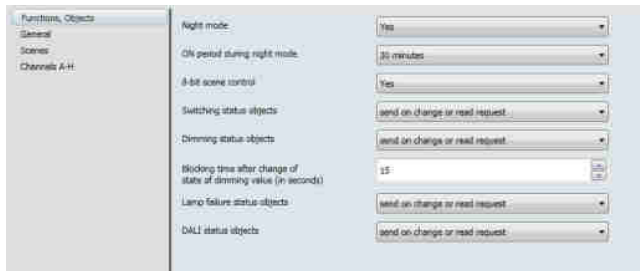

Parameters	Settings
Night mode	No Yes
It is set via this parameter whether the lighting should only be switched ON with a time limit at night (e.g. for cleaning purposes) or whether it should remain switched ON permanently (Night mode = No). If "Night mode = Yes" is selected, a "Night mode ON/OFF" object is added per channel and the following parameter is shown to set the "ON period during night mode" which applies to all the channels.	
ON period during night mode	5 minutes 10 minutes 15 minutes 20 minutes 30 minutes 45 minutes 60 minutes
This parameter defines how long the channel should remain switched ON in night mode. If a switching, dimming, dimming value or scene retrieval command is received before this period has elapsed, the ON period is restarted i.e. it is extended by the parameterised time. If the parameter "Warning before switching OFF" is activated, the relevant channel is dimmed down to half the previous dimming value approx. 30 s before the end of the ON period in order to signal to the room occupant that the lighting will soon be switched OFF. By pressing the ON button again, the channel is immediately dimmed again to the starting value and the timer is restarted.	
8-bit scene control	No Yes
If this parameter is set to "Yes", a communication object "8-bit scene" is added. In addition, a "Scenes" parameter page is displayed which enables each channel to be integrated individually into up to 16 scenes.	
Switching status objects	not present send using read request only send on change or on read request
This parameter defines whether a communication object "Status switching" should be added per channel and when these objects must be sent. If "send on change or on read request" is selected, each change in status is sent. If the setting "send using read request only" is set, there is no automatic sending of the switching state.	
Dimming status objects	not present send using read request only send on change or on read request
This parameter defines whether a communication object "Status dimming value" should be added per channel and when these objects must be sent. If "send on change or on read request" is selected, each change in status is sent. If the setting "send using read request only" is set, there is no automatic sending of the dimming value status.	

Parameters	Settings
Blocking time after change of state of dimming value (in seconds)	15 (1...60)
The parameter "Blocking time after change in state of dimming value" ensures that an unnecessary bus load is not generated due to status telegrams being sent in quick succession when dimming darker/brighter. Once a status telegram is sent, the next telegram is only sent once the blocking time set here has elapsed.	
Lamp failure status objects	not present send using read request only send on change or on read request
It is set via this parameter whether a 1-bit communication object "Status lamp failure" should be added per channel which is used to report a lamp failure on the respective channel and when these objects must be sent. If "send on change or on read request" is selected, each change in status is sent. If "send on read request only" is selected, there is no automatic sending of the lamp failure status.	
DALI status objects	not present send using read request only send on change or on read request
It is set via this parameter whether an 8-bit communication object "Status DALI" should be added per channel and when these objects should be sent. Several faults can be reported via the 8-bit object "Status DALI". If bit 0 is set, a "Lamp failure" is reported. If bit 1 is set, a "Short circuit" of the DALI output is reported. If bit 2 is set, a "Communications failure" is reported i.e. no communication is possible via DALI because none of the DALI devices that are connected to the channel are responding (the DALI bus cable is then either interrupted or the power supply has failed for all the DALI ECGs of this group i.e. there is no AC 230 V present at the ECGs). If "send on change or on read request" is selected, each change in the status is sent. If "send on read request only" is selected, there is no automatic sending of the DALI failure status.	

8.1.2 General

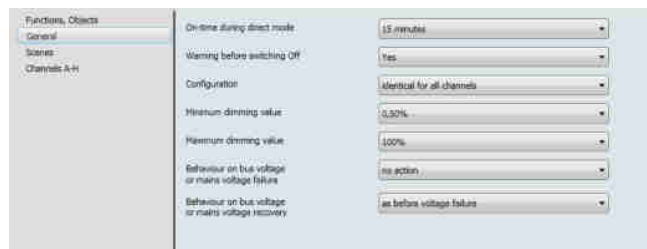

Parameters	Settings
ON time during direct mode	unlimited 5 minutes 10 minutes 15 minutes 20 minutes 30 minutes 45 minutes 60 minutes
It is set via this parameter whether direct mode is switched ON permanently or only for a limited period as well as the time after which the device switches back automatically to BUS mode.	

8. COMMUNICATION OBJECTS (CONTINUED)

8.1.2 General (continued)

Parameters	Settings
Warning before switching Off	Yes No
<p>This parameter specifies whether a channel should signal by reducing the brightness (dimming to 50% of the previous dimming value) in night mode and time switch mode before completely switching OFF the lights. This is carried out approx. 30 seconds before switching OFF.</p> <p>If this parameter is set to "Yes" the parameter "Switching On to" must be set either to "maximum dimming value" or to "last received dimming value".</p>	
Configuration	identical for all channels individual for each channel
<p>It is set via this parameter whether channels A to H should be parameterised together or individually. If "identical for all channels" is selected, only one parameter page is visible for the common configuration of channels A to H while one page per channel is shown when "individual for each channel" is selected.</p>	
Minimum dimming value	0.5% , 1%, 2%, 3%, 4%, 5%, 7%, 10%, 15%, 20%, 30%, 40%, 50%
<p>This parameter defines the minimum dimming value which it is not possible to fall below (i.e. when dimming brighter/darker below the minimum dimming value or on reception of a dimming value smaller than the minimum dimming value, the channel jumps or dims to the minimum dimming value).</p> <p>If the parameter "Switching via dimming brighter/darker" is set to "switching Off possible" or to "switching On and switching OFF possible", dimming darker below the minimum dimming value leads to the respective channel being switched off.</p> <p>If the parameter "Switching via dimming value" is set to "Off if dimming value < min. dimming value", a dimming value below the minimum dimming value leads to the respective channel being switched OFF.</p>	
Maximum dimming value	20%, 30%, 40%, 50%, 60%, 70%, 80%, 90%, 100%
<p>The maximum dimming value which cannot be exceeded when dimming brighter is defined via this parameter. If a dimming value is received which lies above the maximum dimming value, the device only dims or jumps to the maximum dimming value.</p>	
Behaviour on bus voltage or mains voltage failure	no action switch all channels Off set all channels to starting value
<p>The behaviour of the actuator on failure of the EIB bus voltage or the mains voltage is set via this parameter. The actuator channels can no longer be switched via the EIB on bus voltage failure but can still be operated in direct mode. On mains voltage failure, the current switching states and dimming values of all the channels are stored permanently so that they can be recreated if required on mains voltage recovery.</p>	
Behaviour on bus voltage or mains voltage recovery	as before voltage failure switch all channels Off set all channels to starting value
<p>The behaviour of the actuator on recovery of the EIB bus voltage or mains voltage is set via this parameter.</p>	

8.1.3 Scenes

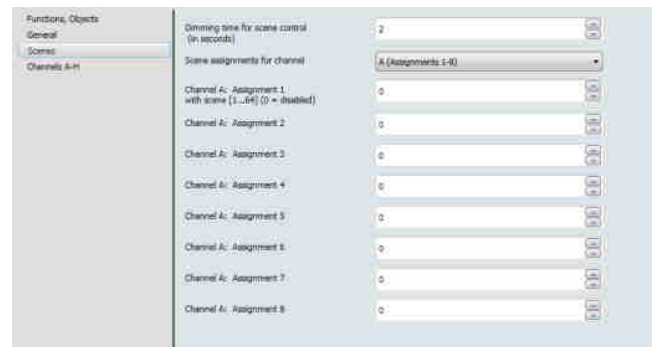

Parameters	Settings
Dimming time for scene control (in seconds)	0-255, 2
<p>This parameter "Dimming time for scene control" sets a common time period for all channels. Once this period has elapsed (on the retrieval of a scene), the dimming process from the previous dimming value to the new dimming value is concluded for all the channels involved in the scene.</p>	
Scene assignments for channel	A (Assignments 1-8) A (Assignments 9-16) B (Assignments 1-8) B (Assignments 9-16) C (Assignments 1-8) C (Assignments 9-16) D (Assignments 1-8) D (Assignments 9-16) E (Assignments 1-8) E (Assignments 9-16) F (Assignments 1-8) F (Assignments 9-16) G (Assignments 1-8) G (Assignments 9-16) H (Assignments 1-8) H (Assignments 9-16)
<p>This parameter determines for which channel the first eight (1-8) or second eight (9-16) scene assignments should be displayed so that they can be modified if necessary.</p>	
Channel A: Assignment 1 with scene [1...64] (0=disabled)	0-64, 0
<p>Channel A can be linked with a scene number in the range 1 to 64 via this parameter. 0 means "no scene assigned" (assignment unused).</p> <p>Note: If a scene is retrieved before a dimming value has been stored for this scene, there is no reaction to the retrieval of this scene.</p>	
Channel A: Assignment 2 with scene [1...64] (0=disabled)	0-64, 0
<p>Channel A can be linked with a further scene number in the range 1 to 64 via this parameter. 0 means "no scene assigned" (assignment unused).</p> <p>Note: If a scene is retrieved before a dimming value has been stored for this scene, there is no reaction to the retrieval of this scene.</p>	
and so on until	
Channel H: Assignment 16 with scene [1...64] (0=disabled)	0-64, 0
<p>Channel H can be linked with a further scene number in the range 1 to 64 via this parameter. 0 means "no scene assigned" (assignment unused).</p> <p>Note: If a scene is retrieved before a dimming value has been stored for this scene, there is no reaction to the retrieval of this scene.</p>	

8. COMMUNICATION OBJECTS (CONTINUED)

8.1.4 Channels A-H

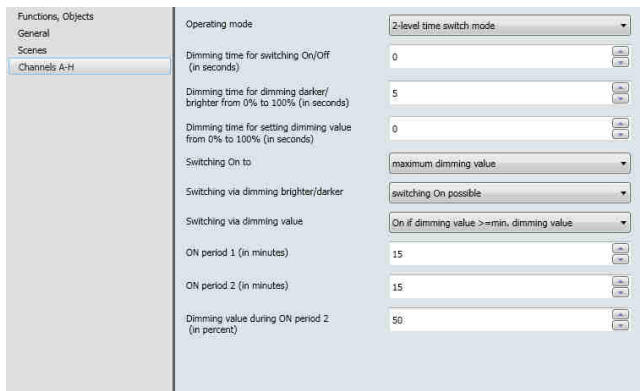

Parameters	Settings
Operating mode	Normal mode 1-level time switch mode 2-level time switch mode
<p>It is set via this parameter whether the channel should operate as a "normal" switching/dimming channel or as a 1-level time switch which is switched ON via a switching, dimming, dimming value or scene retrieval command and is automatically switched OFF once the parameterised period has elapsed or whether it should operate as a 2-level time switch. A 2-level time switch mode is used for staircase and hallway lighting if a complete disconnection of the fluorescent lamps should be avoided once the period has elapsed in order to increase the life time of the lamps. Furthermore, a 2-level time switch is used to control colour lighting.</p> <p>If "1-level time switch mode" is selected, the parameter "ON period (in minutes)" is also displayed. If a switching, dimming, dimming value or scene retrieval command is received in 1-level time switch mode during ON period 1, the timing counter is reset to its initial value and the ON period is extended accordingly.</p> <p>If "2-level time switch mode" is selected, the three parameters "ON period 1 (in minutes)", "ON period 2 (in minutes)" and "Dimming value during ON period 2" are also displayed. While the device is dimmed to 0% at the end of the 1-level time switch mode, it is dimmed in 2-level time switch mode at the end of the first ON period to the "Dimming value during ON period 2", which can lie above or below the previous dimming value. At the end of the 2-level time switch mode, it is then dimmed to 0%.</p> <p>If the warning function has been activated (via the parameter "Warning before switching Off"), approximately 30 s before the ON period has elapsed, the output is dimmed down to half the previous dimming value in order to warn the room occupant that the lighting will switch OFF and to give him sufficient time to press the light switch again so that the lighting is switched ON again for the parameterised period.</p>	
Dimming time for switching On/Off (in seconds)	255, 0
<p>It is set via this parameter whether it should be jumped (dimming time = 0) to the parameterised ON value or to the OFF value 0% or dimmed to these values according to the set time.</p>	
Dimming time for dimming darker/brighter from 0%-100% (in seconds)	1-255, 5
<p>The period for dimming manually from 0% to 100% (or from 100% to 0%) is set via this parameter.</p>	

Parameters	Settings
Dimming time for setting the dimming value from 0%-100% (in seconds)	0-255, 0
<p>It is set via this parameter whether to jump(dimming time = 0) to a new dimming value or to dim to a new value within the set time.</p>	
Switching On to	maximum dimming value dimming value at switching Off last received dimming value
<p>This parameter indicates the starting value on receipt of a telegram with an ON command.</p> <p>The setting "dimming value at switching Off" is beneficial e.g. in a children's room or bedroom. A brief operation of the ON button leads to the device being switched ON at the dimming value that was present before switching OFF. Pressing the ON button again then leads to dimming or jumping to the maximum dimming value.</p> <p>The setting "last received dimming value" is necessary for constant lighting control if the lighting should not be switched OFF by dimming values that lie below the minimum dimming value or switched on by dimming values that lie above this value. The parameter "Switching via dimming value" must therefore be set to "not possible" consequently.</p>	
Switching via dimming brighter/darker	not possible switching On possible switching Off possible switching On and switching Off possible
<p>If it should be possible in the OFF state to switch ON the channel on the reception of a "Brighter" dimming value, this parameter must be set to "switching On possible". In this case, the channel is always switched ON first, the minimum dimming value is reached and then the loads are dimmed brighter by the received "Brighter" dimming value at the parameterised dimming time for dimming brighter/darker.</p> <p>Switching OFF via dimming brighter/darker is not possible in this setting.</p> <p>If it should be possible in the ON state to switch OFF the channel when the brightness is dimmed to a value below the minimum dimming value, this parameter must be set to "switching Off possible". Switching OFF via dimming brighter/darker is not possible in this setting.</p> <p>If it should be possible to switch the channel ON and OFF under the above described conditions, this parameter must be set to "switching On and switching Off possible".</p>	

8. COMMUNICATION OBJECTS (CONTINUED)

8.1.4 Channels A-H (continued)

Parameters	Settings
Switching via dimming value	not possible On if dimming value >= min. dimming value Off if dimming value < min. dimming value switching On and switching Off possible On if dimming value > 0% / Off if dimming value = 0%
<p>If it should be possible in the OFF state to switch ON the channel on the reception of a dimming value which is identical to or greater than the minimum dimming value, this parameter must be set to "On if dimming value >= min. dimming value". The channel is then switched ON and either jumps or dims to the dimming value in accordance with the parameterised dimming time for setting dimming values. If the received dimming value lies below the minimum dimming value, the channel remains switched OFF. Switching OFF by setting the dimming value is not possible in this case.</p> <p>If the channel is switched ON and this parameter is set to "Off if dimming value < min. dimming value", the reception of a telegram with a dimming value lower than the minimum dimming value leads to dimming down (according to the parameterised dimming time for setting dimming values) to the minimum dimming value and then to the switch OFF the channel. Switching ON by setting the dimming value is not possible in this case.</p> <p>If this parameter is set to "Switching On and switching Off possible", the channel is switched ON if the received dimming value is greater than or equal to the minimum dimming value and is switched OFF if the received dimming value lies below the minimum dimming value.</p> <p>If this parameter is set to "On if dimming value > 0% / Off if dimming value = 0%", each dimming value > 0% leads to the channel being switched ON. If the dimming value lies below the minimum dimming value, the channel is set to the minimum dimming value. The channel is only switched ON on the reception of a 0% dimming value.</p>	
ON period 1 (in minutes)	1-255, 15
<p>This parameter sets the desired ON period 1 when "time switch mode" has been selected.</p> <p>If a new switching, dimming, dimming value or scene retrieval command is received during the ON period, the new command is executed, the timer is reset to its initial value and the ON period restarts.</p>	
ON period 2 (in minutes)	1-255, 15
<p>This parameter sets the desired ON period 2 when the "2-level time switch mode" has been selected. If a new switching, dimming, dimming value or scene retrieval command is received during ON period 2, this command is executed, the timer is loaded with ON period 1 and the 2-level time switch restarts.</p>	
Dimming value during ON period 2 (in percent)	1-100, 50
<p>The dimming value during ON period 2 in the 2-level time switch mode is set via this parameter.</p>	