

Technical Data Sheet

Date: 03/11/2022

5x32A CEE N. Angled Panel Mount Socket

Ref. No: 3007-309-1600



Pack Unit

10



Weight

222 gr.



Technical Informations

Quick Connection

Ampere	32A
Voltage	380 - 415 V. AC
Hertz	50 - 60 Hz
Protection Class	IP 44
Clock Position	6h
Number Of Poles	5 (3P + N + E)
Contact Material	Brass (CuZn)
Housing Material	PA6
Connection Type	Quick
Operation Temp.	-25 / +80 (1 hour -100° C)
	(-25 / + 40 IEC 60309)

Dimensions

a	83	e	49
b	90	f	51
c	70	g	100
d	76	Øh	5
Cable Dia. (Flex. Min.)	2,5 mm ²	Øl	72
Cable Dia. (Flex. Max.)	6 mm ²	k	82
Cable Dia. (Rigid Min.)	2,5 mm ²		
Cable Dia. (Rigid Max.)	10 mm ²		

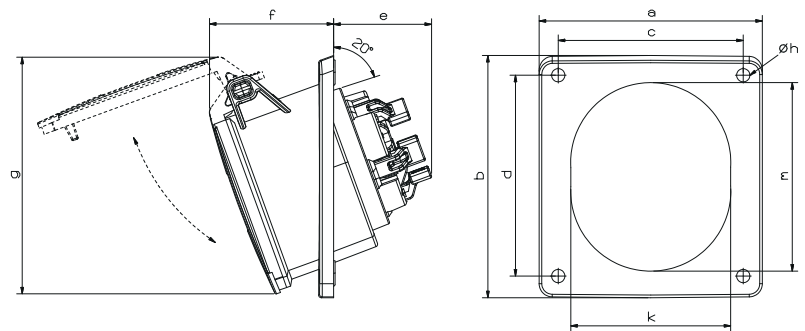

Different Earth Contact Positions (Clock Positions)

 >50V 300-500 Hz 2h	 220/380V 50 Hz 250/440V 60Hz 3h	 57/100V 75/130V 50-60 Hz 4h	 347/600V 400/690V 50-60 Hz 5h	 200/345V 240/415V 50-60 Hz 6h	 277/480V 288/500V 50-60 Hz 7h	 120/208V 144/250V 50-60 Hz 9h	 250/440V 265/460V 60 Hz 11h
3007-309-1100-2h	3007-309-1600-3h	3007-309-0700-4h	3007-309-0300-5h	3007-309-1600	3007-309-0300-7h	3007-309-0900-9h	3007-309-1600-11h



Tel: +90 232 880 90 01
Fax: +90 232 880 90 02



info@tpelectric.com.tr



Kemalpaşa O.S.B. 600 Sk. No:364
35730 Kemalpaşa - İZMİR / TÜRKİYE