

# Technical Data Sheet

Date: 03/11/2022

## 3x16A CEE N. Angled Panel Mount Socket

Ref. No: 3021-309-0900



Pack Unit

10



Weight

157 gr.



## Technical Informations

Quick Connection

<b>Ampere</b>	16A
<b>Voltage</b>	200 - 250 V. AC
<b>Hertz</b>	50 - 60 Hz
<b>Protection Class</b>	IP 67
<b>Clock Position</b>	6h
<b>Number Of Poles</b>	3 (2P + E)
<b>Contact Material</b>	Brass (CuZn)
<b>Housing Material</b>	PA6
<b>Connection Type</b>	Quick
<b>Operation Temp.</b> (-25 / + 40 IEC 60309)	-25 / +80 (1 hour -100° C)

## Dimensions

<b>a</b>	83	<b>e</b>	37
<b>b</b>	90	<b>f</b>	50
<b>c</b>	70	<b>g</b>	103
<b>d</b>	76	<b>k</b>	5
<b>Cable Diameter (Min.)</b>	1 mm <sup>2</sup>	<b>Øh</b>	52
<b>Cable Diameter (Max.)</b>	2,5 mm <sup>2</sup>	<b>M</b>	65
<b>Cable Diameter (Rigid)</b>	1 mm <sup>2</sup>		
<b>Cable Diameter (Rigid)</b>	4 mm <sup>2</sup>		

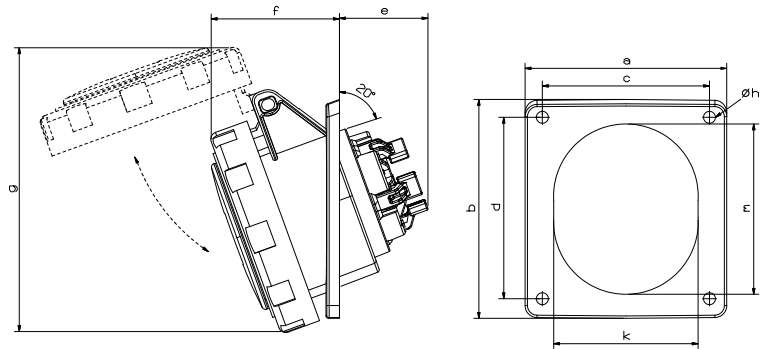

## Different Earth Contact Positions (Clock Positions)

 >50V 300-500 Hz 2h	 100-130V 50-60 Hz 4h	 200-250V 50-60 Hz 6h	 480-500V 50-60 Hz 7h	 380-415V 50-60 Hz 9h
3021-309-1100-2h	3021-309-0700-4h	3021-309-0900	3021-309-0300-7h	3021-309-1600-9h



Tel: +90 232 880 90 01  
Fax: +90 232 880 90 02



info@tpelectric.com.tr



Kemalpaşa O.S.B. 600 Sk. No:364  
35730 Kemalpaşa - İZMİR / TÜRKİYE