

10426500	DATA SHEET	
Valid from: 20.11.2024	EPIC® H-A 3 MTG	

Description

- Innovative metal housing
- For safe connections in the smallest possible space

General characteristics

Series	H-A 3
Version	Hood
Locking mechanism	Bolts for single lever
Cable entry	Straight
Cable gland	See table
Clamping range	See table
Protection rating (DIN EN 60529)	IP 66 (latched) IP 68 - 1 meter / 10 hours (latched)
Protection rating (NEMA 250, UL50E)	4, 12 (latched)
Temperature range	-40 °C to +100 °C, short-term up to +125 °C



Materials and surfaces

Housing, base material	Zinc die-casting
Housing, surface	Powder-coating, grey
Pressure screw	Brass, nickel-plated
Pressure washer	Steel, zinc-plated
Sealing ring	NBR (Pg 11), CR (M20)

Standard

Safety Standard	IEC 61984, UL50E
-----------------	------------------

Approvals

UL-Approval, E-File-Number	E75770
----------------------------	--------

Versions

Article number	Article description	Thread	Cable gland	Clamping range	Dimension C
10512100	EPIC® H-A 3 MTG 11 N.GEW. HOOD	Pg 11	No	-	50,2
10426500	EPIC® H-A 3 MTG 11 KPL. HOOD	Pg 11	Yes	6,5 - 12 mm	57
19512100	EPIC® H-A 3 MTG M20 N.GEW. HOOD	M20	No	-	50,2
19426500	EPIC® H-A 3 MTG M20 KPL. HOOD	M20	Yes	3 - 13,5 mm	58

Creator: THBO1/BU-EPIC Released: VACH1/BU-EPIC	Document: DB10426500EN Version: 03	Page 1 of 2
---	---------------------------------------	-------------

10426500	DATA SHEET	
Valid from: 20.11.2024	EPIC® H-A 3 MTG	

Technical Drawings

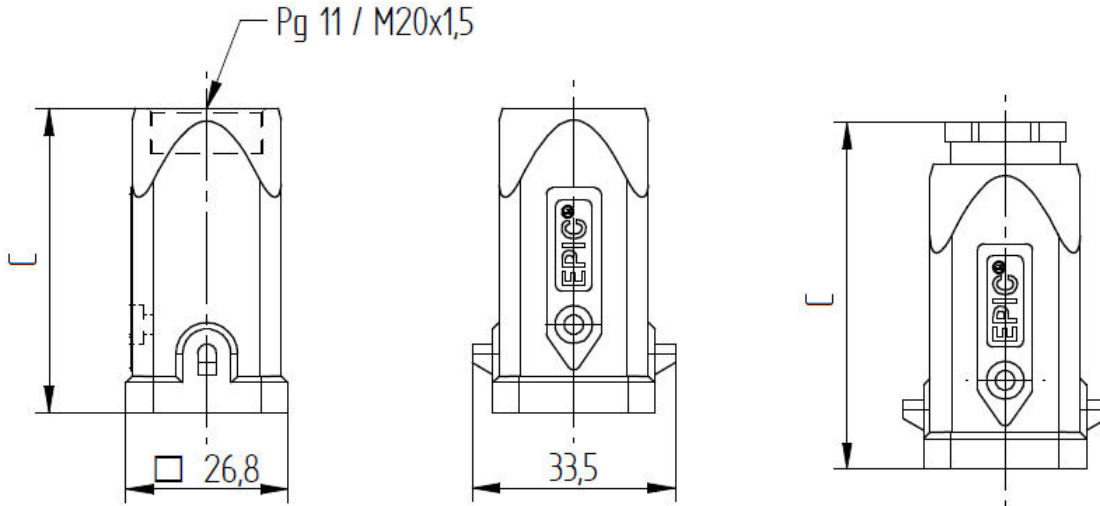

Industrial machinery and plant engineering



Mechanical resistance



Robust



Waterproof

Info

Compact, robust metal housings size H-A 3

Application range

Machine and equipment manufacturing
Control engineering
Electronic laboratory

Remark

Photographs are not to scale and do not represent detailed images of the respective products.

Creator: THBO1/BU-EPIC Released: VACH1/BU-EPIC	Document: DB10426500EN Version: 03	Page 2 of 2
---	---------------------------------------	-------------